



FRONTRUNNER™

AIR-COOLED MODELS

**For Serial Nos.
720,000 & Higher**
Part No. 4500-218 Rev. A

Operator's Manual

⚠ WARNING

CALIFORNIA Proposition 65 Warning

The engine exhaust from this product contains chemicals known to the State of California to cause cancer, birth defects, or other reproductive harm.

Important: When the mower is used or operated on any California forest, brush or grass covered land, a working spark arrester must be attached to the muffler. If not, the operator is violating state law, Section 4442 Public Resource Code. To acquire a spark arrester for your unit, see your Engine Service Dealer.

This spark ignition system complies with Canadian ICES-002 Ce système d'allumage par étincelle de véhicule est conforme à la norme NMB-002 du Canada

The enclosed Engine Owner's Manual is supplied for information regarding The U.S. Environmental Protection Agency (EPA) and the California Emission Control Regulation of emission systems, maintenance and warranty.

Keep this engine Owner's Manual with your unit. Should this engine Owner's Manual become damaged or illegible, replace immediately. Replacements may be ordered through the engine manufacturer.

Exmark reserves the right to make changes or add improvements to its products at any time without incurring any obligation to make such changes to products manufactured previously. Exmark, or its distributors and dealers, accept no responsibility for variations which may be evident in the actual specifications of its products and the statements and descriptions contained in this publication.



If your Exmark dealer does not have the Exmark part in stock, Exmark will get the parts to the dealer the next business day or the part will be FREE Guaranteed!! (Some restrictions apply. See your participating Exmark Dealer for details.)

Introduction

CONGRATULATIONS on the purchase of your Exmark Mower. This product has been carefully designed and manufactured to give you a maximum amount of dependability and years of trouble-free operation.

This manual contains operating, maintenance, adjustment, and safety instructions for your Exmark mower.

BEFORE OPERATING YOUR MOWER, CAREFULLY READ THIS MANUAL IN ITS ENTIRETY.

By following the operating, maintenance, and safety instructions, you will prolong the life of your mower, maintain its maximum efficiency, and promote safe operation.

If additional information is needed, or should you require trained mechanic service, contact your authorized Exmark equipment dealer or distributor.

All Exmark equipment dealers and distributors are kept informed of the latest methods of servicing and are equipped to provide prompt and efficient service in the field or at their service stations. They carry ample stock of service parts or can secure them promptly for you from the factory.

All Exmark parts are thoroughly tested and inspected before leaving the factory, however, attention is required on your part if you are to obtain the fullest measure of satisfaction and performance.

Whenever you need service, genuine Exmark parts, or additional information, contact an Authorized Service Dealer or Exmark Customer Service and have the model and serial numbers of your product ready.

Figure 1 identifies the location of the model and serial numbers on the product. Write the numbers in the space provided.

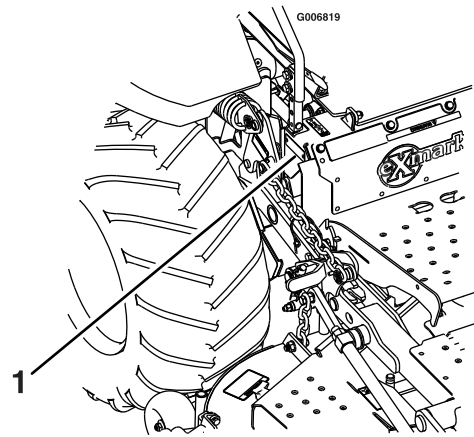

Figure 1

1. Model and serial number location

Model No. _____
Serial No. _____

Contents

Introduction	3	Weight Transfer Spring Adjustment	33
Safety	5	Caster Pivot Bearings Pre-Load	
Safety Alert Symbol.....	5	Adjustment	34
Safe Operating Practices	5	Cleaning	34
Safety and Instructional Decals	10	Clean Engine Cooling System	34
Specifications	14	Remove Accumulated Debris from	
Model Numbers	14	Engine (Briggs & Stratton Units	
Systems	14	Only).....	34
Dimensions.....	16	Remove Engine Shrouds and Clean Cooling	
Torque Requirements	17	Fins.....	35
Product Overview	17	Waste Disposal.....	35
Operation	18	Troubleshooting	36
Controls	18	Schematics	38
Pre-Start.....	19		
Operating Instructions	19		
Transporting	22		
Maintenance	23		
Recommended Maintenance Schedule(s)	23		
Periodic Maintenance	24		
Check Engine Oil Level	24		
Check Battery Charge.....	24		
Check Safety Interlock System	25		
Check Rollover Protections Systems (Roll			
Bar) Pins	26		
Check Seat Belt.....	26		
Check for Loose Hardware	26		
Service Air Cleaner	26		
Change Engine Oil.....	26		
Check Hydraulic Oil Level	27		
Check Tire Pressures	27		
Check Condition Of Belts.....	28		
Lubricate Grease Fittings.....	28		
Lubricate Rear Caster Wheel Hub(s).....	28		
Lubricate Brake Handle Pivot	29		
Lubricate Brake Rod Bushings	29		
Lubricate Motion Control Bronze			
Bushings	29		
Lubricate Motion Control Shaft	29		
Lubricate Steering Linkage Rod Ends.....	29		
Check Spark Plugs	30		
Change Hydraulic System Filter	30		
Check Wheel Hub Locknuts	30		
Thread Locking Adhesives.....	30		
Dielectric Grease.....	31		
Adjustments	31		
Pump Drive Belt Tension.....	31		
Pump Drive Belt Replacement	31		
Park Brake Adjustment	31		
Motion Control Linkage Adjustment	32		

Safety

Safety Alert Symbol

This Safety Alert Symbol (Figure 2) is used both in this manual and on the machine to identify important safety messages which must be followed to avoid accidents

This symbol means: **ATTENTION! BECOME ALERT! YOUR SAFETY IS INVOLVED!**



Figure 2

1. Safety alert symbol

The safety alert symbol appears above information which alerts you to unsafe actions or situations and will be followed by the word **DANGER**, **WARNING**, or **CAUTION**.

DANGER: White lettering / Red background. Indicates an imminently hazardous situation which, if not avoided, **Will** result in death or serious injury.

WARNING: Black lettering / Orange background. Indicates a potentially hazardous situation which, if not avoided, **Could** result in death or serious injury.

CAUTION: Black lettering / Yellow background. Indicates a potentially hazardous situation which, if not avoided, **May** result in minor or moderate injury.

This manual uses two other words to highlight information. **Important** calls attention to special mechanical information and **Note** emphasizes general information worthy of special attention.

Safe Operating Practices

Training

- Read the Operator's Manual and other training material. If the operator(s) or mechanic(s) can not read English it is the owner's responsibility to explain this material to them.
- Become familiar with the safe operation of the equipment, operator controls, and safety signs.
- All operators and mechanics should be trained. The owner is responsible for training the users.

- Never let children or untrained people operate or service the equipment. Local regulations may restrict the age of the operator.
- The owner/user can prevent and is responsible for accidents or injuries occurring to himself or herself, other people or property.

Preparation

- Evaluate the terrain to determine what accessories and attachments are needed to properly and safely perform the job. Only use accessories and attachments approved by Exmark.
- Wear appropriate clothing including safety glasses, substantial footwear, long trousers, and hearing protection. Do Not operate when barefoot or when wearing open sandals. Long hair, loose clothing or jewelry may get tangled in moving parts.

⚠ CAUTION

This machine produces sound levels in excess of 85 dBA at the operator's ear and can cause hearing loss through extended periods of exposure.

Wear hearing protection when operating this machine.

- Inspect the area where the equipment is to be used and remove all rocks, toys, sticks, wires, bones, and other foreign objects which can be thrown by the machine and may cause personal injury to the operator or bystanders.

⚠ DANGER

In certain conditions gasoline is extremely flammable and vapors are explosive.

A fire or explosion from gasoline can burn you, others, and cause property damage.

- Fill the fuel tank outdoors in an open area, when the engine is cold. Wipe up any gasoline that spills.
- Never refill the fuel tank or drain the machine indoors or inside an enclosed trailer.
- Do Not fill the fuel tank completely full. Add gasoline to the fuel tank until the level is 1/4 to 1/2 inch (6–13 mm) below the bottom of the filler neck. This empty space in the tank allows gasoline to expand.
- Never smoke when handling gasoline, and stay away from an open flame or where gasoline fumes may be ignited by spark.
- Store gasoline in an approved container and keep it out of the reach of children.
- Add fuel before starting the engine. Never remove the cap of the fuel tank or add fuel when engine is running or when the engine is hot.
- If fuel is spilled, Do Not attempt to start the engine. Move away from the area of the spill and avoid creating any source of ignition until fuel vapors have dissipated.
- Do Not operate without entire exhaust system in place and in proper working condition.

⚠ DANGER

In certain conditions during fueling, static electricity can be released causing a spark which can ignite gasoline vapors. A fire or explosion from gasoline can burn you and others and cause property damage.

- Always place gasoline containers on the ground away from your vehicle before filling.
- Do Not fill gasoline containers inside a vehicle or on a truck or trailer bed because interior carpets or plastic truck bed liners may insulate the container and slow the loss of any static charge.
- When practical, remove gas-powered equipment from the truck or trailer and refuel the equipment with its wheels on the ground.
- If this is not possible, then refuel such equipment on a truck or trailer from a portable container, rather than from a gasoline dispenser nozzle.
- If a gasoline dispenser nozzle must be used, keep the nozzle in contact with the rim of the fuel tank or container opening at all times until fueling is complete.

⚠ WARNING

Gasoline is harmful or fatal if swallowed. Long-term exposure to vapors has caused cancer in laboratory animals. Failure to use caution may cause serious injury or illness.

- Avoid prolonged breathing of vapors.
 - Keep face away from nozzle and gas tank/container opening.
 - Keep away from eyes and skin.
 - Never siphon by mouth.
- Check that the operator's presence controls, safety switches, and shields are attached and functioning properly. Do Not operate unless they are functioning properly.

Operation

WARNING

Operating engine parts, especially the muffler, become extremely hot. Severe burns can occur on contact and debris, such as leaves, grass, brush, etc. can catch fire.

- Allow engine parts, especially the muffler, to cool before touching.
- Remove accumulated debris from muffler and engine area.
- Install and maintain in working order a spark arrester before using equipment on forest-covered, grass-covered, or brush-covered unimproved land.

WARNING

Engine exhaust contains carbon monoxide, which is an odorless deadly poison that can kill you.

Do Not run engine indoors or in a small confined area where dangerous carbon monoxide fumes can collect.

WARNING

Operating a FrontRunner tractor without an approved Exmark front mount attachment increases the possibility of forward tip over. Tip-over could cause serious injury or death.

When operating a FrontRunner tractor without an approved Exmark front mount attachment, observe the following:

- Limit operation to minimum required to install a different front mount attachment.
 - Minimize speed and use extreme caution.
 - Only operate on a flat level surface.
 - Do Not operate up or down a trailer ramp.
 - Avoid sudden acceleration or deceleration.
- Operate only in daylight or good artificial light, keeping away from holes and hidden hazards.

- Be sure all drives are in neutral and parking brake is engaged before starting engine. Use seat belts.
- Never operate the mower with damaged guards, shields, or covers. Always have safety shields, guards, switches and other devices in place and in proper working condition.
- Never mow with the discharge deflector raised, removed or altered unless there is a grass collection system or mulch kit in place and working properly.
- Do Not change the engine governor setting or overspeed the engine.
- Stop engine, wait for all moving parts to stop, remove key and engage parking brake:
 - Before checking, cleaning or working on the mower.
 - After striking a foreign object or abnormal vibration occurs (inspect the mower for damage and make repairs before restarting and operating the mower).
 - Before clearing blockages.
 - Whenever you leave the mower.
- Stop engine, wait for all moving parts to stop, and engage parking brake:
 - Before refueling.
 - Before dumping the grass catcher.

WARNING

Hands, feet, hair, clothing, or accessories can become entangled in rotating parts. Contact with the rotating parts can cause traumatic amputation or severe lacerations.

- Do Not operate the machine without guards, shields, and safety devices in place and working properly.
 - Keep hands, feet, hair, jewelry, or clothing away from rotating parts.
- **NEVER** carry passengers. **DO NOT** operate the mower when people, especially children, or pets are in the area.
 - Be alert, slow down and use caution when making turns. Look behind and to the side before changing directions.
 - Stop the blades, slow down, and use caution when crossing surfaces other than grass and when

Safety

transporting the mower to and from the area to be mowed.

- Be aware of the mower discharge path and direct discharge away from others.
- Do Not operate the mower under the influence of alcohol or drugs.
- Use extreme care when loading or unloading the machine into a trailer or truck.
- Use care when approaching blind corners, shrubs, trees, or other objects that may obscure vision.

Slope Operation

Use **Extreme** caution when mowing and/or turning on slopes as loss of traction and/or tip-over could occur. The operator is responsible for safe operation on slopes.

⚠ DANGER

Operating on wet grass or steep slopes can cause sliding and loss of control. Wheels dropping over edges, ditches, steep banks, or water can cause rollovers, which may result in serious injury, death or drowning.

- **Do Not** mow slopes when grass is wet.
 - **Do Not** mow near drop-offs or near water.
 - **Do Not** mow slopes greater than 15 degrees.
 - **Reduce speed and use extreme caution on slopes.**
 - **Avoid sudden turns or rapid speed changes.**
- See inside the back cover to determine the approximate slope angle of the area to be mowed.
 - Use a walk behind mower and/or a hand trimmer near drop-offs, ditches, steep banks or water. (Figure 3).

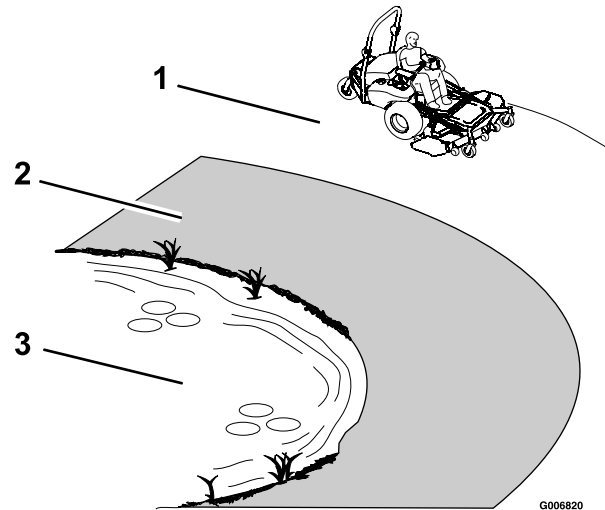

Figure 3

1. **Safe Zone**-Use the mower here on slopes less than 15 degrees
2. **Danger Zone**-Use a walk behind mower and/or hand trimmer near drop-offs and water.
3. **Water**

- Remove or mark obstacles such as rocks, tree limbs, etc. from the mowing area. Tall grass can hide obstacles.
- Watch for ditches, holes, rocks, dips and rises that change the operating angle, as rough terrain could overturn the machine.
- Avoid sudden stops when mowing downhill because the mower may tip forwards.
- Be aware that loss of traction may occur going uphill. Weight transfer to the rear wheels may cause drive wheels to slip and cause loss of braking and steering.
- Always avoid sudden starting or stopping on a slope. If tires lose traction, disengage the blades and proceed slowly off the slope.
- Follow the manufacturer's recommendations for wheel weights or counter weights to improve stability.
- Use extreme care with grass catchers or attachments. These can change the stability of the machine and cause loss of control.

Using the Rollover Protection System (ROPS)

A Rollover Protection System (roll bar) is installed on the unit.

⚠ WARNING

There is no rollover protection when the roll bar is down. Wheels dropping over edges, ditches, steep banks, or water can cause rollovers, which may result in serious injury, death or drowning.

- **Keep the roll bar in the raised and locked position and use seat belt.**
- **Lower the roll bar only when absolutely necessary.**
- **Do Not wear seat belt when the roll bar is down.**
- **Drive slowly and carefully.**
- **Raise the roll bar as soon as clearance permits.**

- Check carefully for overhead clearances (i.e. branches, doorways, and electrical wires) before driving under any objects and Do Not contact them.

Maintenance and Storage

- Disengage drives, lower implement, set parking brake, stop engine and remove key or disconnect spark plug wire. Wait for all movement to stop before adjusting, cleaning or repairing.
- Keep engine, engine area, and pump drive belt compartment free from accumulation of grass, leaves, excessive grease or oil, and other debris which can accumulate in these areas. These materials can become combustible and may result in a fire.
- Let engine cool before storing and Do Not store near flame or any enclosed area where open pilot lights or heat appliances are present.
- Shut off fuel while storing or transporting. Do Not store fuel near flames or drain indoors.
- Park machine on level ground. Never allow untrained personnel to service machine.
- Use jack stands to support components when required.
- Carefully release pressure from components with stored energy.
- Disconnect battery or remove spark plug wire before making any repairs. Disconnect the

negative terminal first and the positive last. Reconnect positive first and negative last.

- Use care when checking blades. Wrap the blade(s) or wear gloves, and use caution when servicing them. Only replace blades. Never straighten or weld them.
- Keep hands and feet away from moving parts. If possible, Do Not make adjustments with the engine running.
- Charge batteries in an open well ventilated area, away from spark and flames. Unplug charger before connecting or disconnecting from battery. Wear protective clothing and use insulated tools.
- Keep all guards, shields and all safety devices in place and in safe working condition.
- Check all bolts frequently to maintain proper tightness.
- Frequently check for worn or deteriorating components that could create a hazard.
- All replacement parts must be the same as or equivalent to the parts supplied as original equipment.

⚠ WARNING

Hydraulic fluid escaping under pressure can penetrate skin and cause injury. Fluid accidentally injected into the skin must be surgically removed within a few hours by a doctor familiar with this form of injury or gangrene may result.

- **Make sure all hydraulic fluid hoses and lines are in good condition and all hydraulic connections and fittings are tight before applying pressure to hydraulic system.**
- **Keep body and hands away from pinhole leaks or nozzles that eject high pressure hydraulic fluid.**
- **Use cardboard or paper, not your hands, to find hydraulic leaks.**
- **Safely relieve all pressure in the hydraulic system by placing the motion control levers in neutral and shutting off the engine before performing any work on the hydraulic system.**

Safety

Safety and Instructional Decals

- Keep all safety signs legible. Remove all grease, dirt and debris from safety signs and instructional labels.
- Replace all worn, damaged, or missing safety signs.
- When replacement components are installed, be sure that current safety signs are affixed to the replaced components.
- If an attachment or accessory has been installed, make sure current safety signs are visible.
- New safety signs may be obtained from your authorized Exmark equipment dealer or distributor or from Exmark Mfg. Co. Inc.
- Safety signs may be affixed by peeling off the backing to expose the adhesive surface. Apply only to a clean, dry surface. Smooth to remove any air bubbles.
- Familiarize yourself with the following safety signs and instruction labels. They are critical to the safe operation of your Exmark commercial mower.



103-2076



1-513747



1-523552

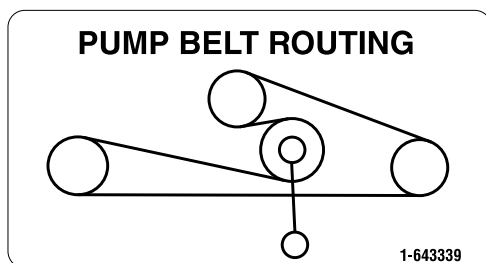

1-643339



98-4361



98-5954

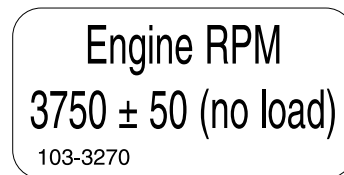

103-3270



103-5881

⚠ WARNING

ROTATING FAN BLADES
Can cause serious injury.

- DO NOT operate without guards in place.
- Stop engine before removing guards.

103-7218



103-7218

⚠ WARNING

- Operating on wet grass or steep slopes can cause sliding and loss of control.
- Wheels dropping over edges can cause rollovers, which may result in serious injury, death or drowning.
- To avoid loss of control and possibility of rollover:
 - Do NOT operate near drop-offs or near water.
 - Do NOT operate on slopes greater than 15°.
 - Reduce speed and use extreme caution on slopes.
 - Avoid sudden turns or rapid speed changes.
- There is no rollover protection when the roll bar is down.
- Always keep roll bar in the raised and locked position and use seat belt.
- Read and follow rollover protection instructions and warning.

107-2112



Greater than 15°



107-2112

⚠ WARNING



TO AVOID INJURY OR DEATH FROM ROLLOVER:

Keep roll bar in the raised and locked position and use seat belt.



THERE IS NO ROLL OVER PROTECTION WHEN THE ROLL BAR IS DOWN.

Lower the roll bar only when absolutely necessary.

Do not wear seat belt when the roll bar is down.

Drive slowly and carefully.

Raise the roll bar as soon as clearance permits.

Read and follow slope operation instructions and warnings.

107-2102

107-2102

⚠ WARNING

SPRING LOADED MECHANISM
Can cause serious injury.

- See operator's manual for disassembly procedure.

109-2355

109-2355

MOTION CONTROL



109-2356

109-2356

- 1. Fast
- 2. Slow
- 3. Neutral
- 4. Reverse

Safety

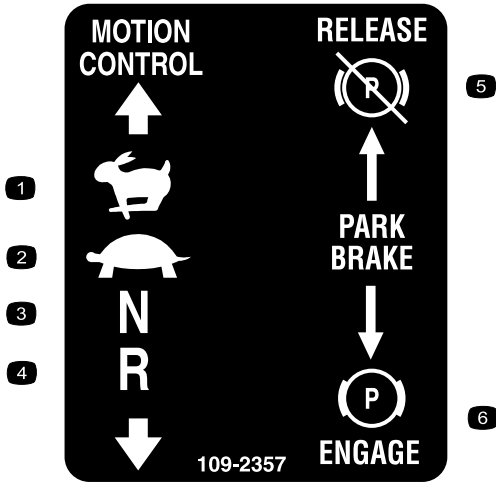

- 1. Fast
- 2. Slow
- 3. Neutral
- 4. Reverse
- 5. Park Brake—Release
- 6. Park Brake—Engage



109-2396

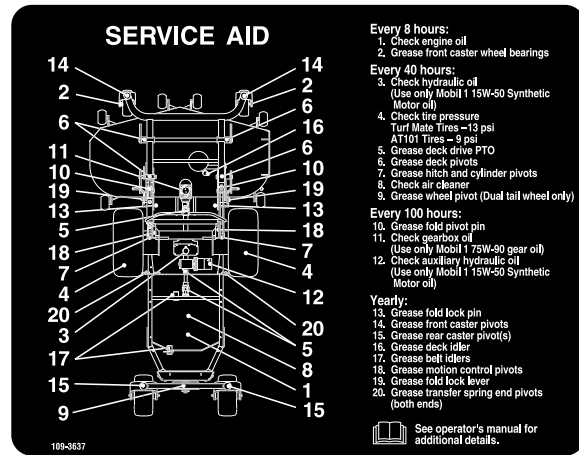

109-3637

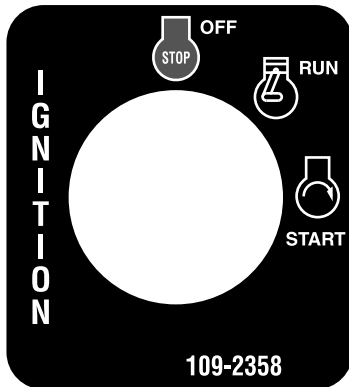

109-2358



109-2377

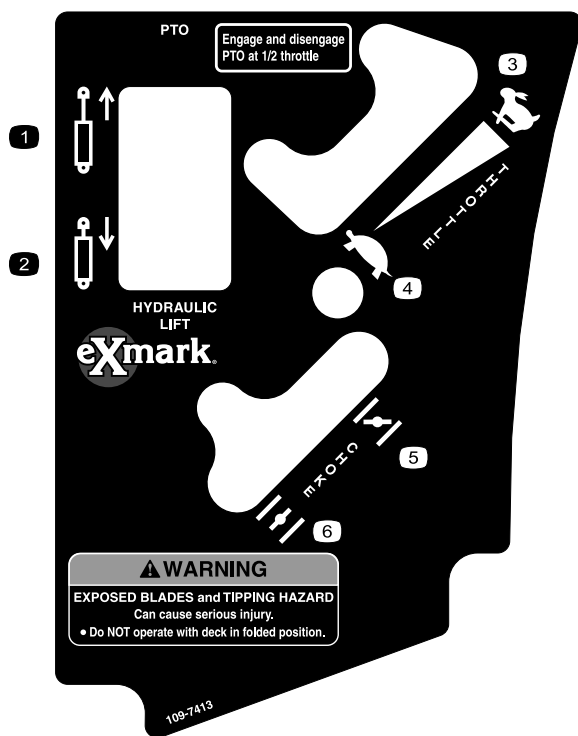

109-7413

- | | |
|---------------------|--------------|
| 1. Cylinder—extend | 4. Slow |
| 2. Cylinder—retract | 5. Choke—on |
| 3. Fast | 6. Choke—off |

Torque Wheel Lug Nuts to 90-95 ft-lbs (122-129 N-m). Torque Wheel Hub Slotted Nut to 125 ft-lbs (169 N-m) min. See Operator's Manual for more details.	Check after first 100 hrs then every 500 hrs thereafter.
--	--

109-7949

- Do NOT operate under the influence of alcohol or drugs.
- Do NOT operate without shields, guards, and safety devices in place and working.
- Check the function of the operator presence controls (OPC) safety system daily. Do NOT defeat the OPC system.
- Stop engine and remove key before adjusting, servicing or cleaning machine and attachments.
- Do NOT carry passengers.

WARNING

- To avoid serious injury or death:**
- Read and understand the operator's manual before using this machine.
 - Do NOT operate unless trained to safely use this machine.

- Look behind and to the side before changing directions.
- Hearing protection is recommended.
- Before leaving the operator's position:
 - Disengage PTO.
 - Move drive levers out to neutral lock position.
 - Engage park brake.
 - Stop engine.

109-2360

109-2360

Specifications

Model Numbers

Serial Nos: 720,000 and Higher

FR23KC; FR27KC; FR31BV

Systems

Engine

- Engine Specifications: See your Engine Owner's Manual
- RPM: Full Speed: 3750 ±50 RPM (No Load)
Idle: 1500 RPM

Fuel System

- Capacity: 8.5 gal. (32 L)
- Type of Fuel: Regular unleaded gasoline, 87 octane or higher.
- Fuel Filter:
 - Kohler:
In-line 15 Micron Kohler P/N 2405010.
 - Briggs & Stratton:
In-line 30 Micron Briggs P/N 695327.
- Fuel Shut-Off Valve: 1/4 turn increments (“ON”, “OFF”).
- Fuel gauge in right hand fuel tank.

Electrical System

- Charging System: Flywheel Alternator
- Charging Capacity:
 - Kohler: 15 amps
 - Briggs & Stratton: 20 amps
- Battery Type: BCI Group U1
- Battery Voltage: 12 Volt
- Polarity: Negative Ground
- Fuses:
 - Kohler:
One 15 amp and two 20 amp blade type
 - Briggs & Stratton:
One 15 amp, one 20 amp, and one 30 amp blade type

Safety Interlock System

- PTO must be disengaged, brake engaged, and motion control levers out (neutral lock) to start engine. (It is not necessary for the operator to be in the seat to start the engine.)
- Operator must be in seat when PTO is engaged, brake is disengaged, or motion control levers are moved in or engine will stop.
- Engine will stop if the motion control levers are moved from neutral position while brake is engaged.

Operator Controls

- Steering and Motion Control:

Note: Motion control levers are adjustable to three heights.

- Separate levers, on each side of the console, control speed and direction of travel of the respective drive wheels.
- Steering is controlled by varying the position of the levers relative to each other.
- Moving motion control levers outward (in slots) locks the drive system in neutral.
- PTO Engagement Lever: Engages drive to PTO (mower deck).
- Parking Brake Lever: Engages parking brake by pulling back.

Seat

- Type: Standard seat with high back, foam padded (internal suspension) and armrests and integral safety switch.

Optional seat accessories:

- Custom ride suspension system to enhance Standard Seat.
- Deluxe suspension seat with high back, low profile foam-in-place cushion (dampened, adjustable spring suspension) and armrests.

- **Mounting:** Hinged to tilt up for access to hydraulic pumps, battery and other components. The seat is held in the tilted position with a linkage. Adjustable fore and aft seat track.
- **Armrests:** Standard seat: foam padded flip-up armrests. Optional suspension seat: molded adjustable flip-up armrests.
- **Seat Safety Switch:** Internal to the bottom seat cushion, non serviceable. Time delay module incorporated into the Safety Interlock System eliminates rough ground cut-outs.

Hydrostatic Ground Drive System

- **Hydrostatic Pumps:**
 - 27HP Kohler & 31HP Briggs & Stratton Units: Two Hydro Gear PR 16 cc variable displacement piston pumps.
 - 23HP Kohler Units: Two Hydro Gear PJ 12 cc variable displacement piston pumps.
- **Wheel Motors:** Hydro Gear planetary reduction motors.
- **Hydraulic Oil Type:** Use Mobil 1 15W-50 Synthetic motor oil.
- **Hydraulic Oil Capacity:**
 - 27HP Kohler & 31HP Briggs & Stratton Units: 5.2 qt. (4.9 L)
 - 23HP Kohler Units: 4.0 qt. (3.8 L)
- **Hydraulic Filter:** Replaceable cartridge type. P/N 103-2146: 25 microns, No bypass
- **Speeds:**
 - 27HP Kohler & 31HP Briggs & Stratton Units:
 - 0-10.5 mph (16.9 km/hr) forward
 - 0-6.6mph (10.6 km/hr) reverse
 - 23HP Kohler Units:
 - 0-8.7 mph (14.0 km/hr) forward
 - 0-5.7mph (9.2 km/hr) reverse
- **Drive wheel release valves** allow machine to be moved when engine is not running.

Tires & Wheels

27HP Kohler & 31HP Briggs & Stratton Units

	Drive	Front Caster	Rear Caster (Dual Tail Wheel)
	Pneumatic (Air-Filled)	Semi-Pneumatic	Semi-Pneumatic
Quantity	2	2	2
Tread	AT101	Smooth	Smooth
Size	24 x 12.00-12	9 x 3.50-4	13 x 6.5-6
Ply Rating	4		
Pressure	9 psi (62 kPa)		

23HP Kohler Units

	Drive	Front Caster	Rear Caster (Single Tail Wheel)
	Pneumatic (Air-Filled)	Semi-Pneumatic	Semi-Pneumatic
Quantity	2	2	1
Tread	Turfmate	Smooth	Smooth
Size	23 x 10.50-10	9 x 3.50-4	13 x 6.5-6
Ply Rating	4		
Pressure	13 psi (90 kPa)		

Cutting Deck

(Sold Separately)

- **Model Numbers:**
 - FR524
 - FR604
 - FR724
- **Cutting Width:**
 - 52 inch (132 cm)
 - 60 inch (152 cm)
 - 72 inch (183 cm)
- **Discharge:** Side
- **Blade Size:** (3 ea.)
 - 52 inch Deck: 18.00 inches (45.7 cm)

Specifications

- 60 inch Deck: 20.50 inches (52.1 cm)
- 72 inch Deck: 24.50 inches (62.2 cm)
- Blade Spindles: Solid steel spindles with 1 3/4 inch (4.45 cm) I.D. bearings.
- Deck Drive: “B”-Section belt from jackshaft on deck to blade spindles.
- Deck: Full floating deck is attached to out-front support frame, removable for service. Six anti-scalp rollers provide maximum turf protection. Deck design allows for bagging, mulching or side discharge.
- Deck Depth:
 - 52 inch Deck: 5.5 inches (14.0 cm)
 - 60 inch Deck: 5.5 inches (14.0 cm)
 - 72 inch Deck: 5.5 inches (14.0 cm)
- Cutting Height Adjustment: Adjusts from 1 1/2 inches (3.8 cm) to 5 inches (12.7 cm) infinitely variable.
- Mulching Kit: Optional
- Bagger: Optional

	23HP Kohler	27HP Kohler & 31HP Briggs & Stratton
60 inch Deck	112.4 inches (285.5 cm)	114.3 inches (290.3 cm)
72 inch Deck		114.3 inches (290.3 cm)

Overall Height:

Roll Bar - Up	Roll Bar - Down
69.2 inches (175.8 cm)	50.7 inches (128.8 cm)

Tread Width: (Center to Center of Tires, Widthwise)

27HP Kohler & 31 HP Briggs & Stratton Units

52 inch Deck	60 inch Deck	72 inch Deck
41.4 inches (105.2 cm)	41.4 inches (105.2 cm)	45.4 inches (115.3 cm)

23HP Kohler Units

52 inch Deck	60 inch Deck	72 inch Deck
38.9 inches (98.8 cm)	38.9 inches (98.8 cm)	

Dimensions

Overall Width:

	52 inch Deck	60 inch Deck	72 inch Deck
Without Deck	49.0 inches (124.5 cm)	49.0 inches (124.5 cm)	53.0 inches (135 cm)
Deflector Up	53.3 inches (135.4 cm)	61.4 inches (156 cm)	73.4 inches (186 cm)
Deflector Down	64.0 inches (163 cm)	72.0 inches (183 cm)	84.3 inches (214 cm)

Overall Length:

	23HP Kohler	27HP Kohler & 31HP Briggs & Stratton
Without deck and floor pan folded	80.4 inches (204.2 cm)	82.3 inches (209.0 cm)
52 inch Deck	112.4 inches (285.5 cm)	114.3 inches (290.3 cm)

Wheel Base: (Center of Caster Tire to Center of Drive Tire)

- 27HP Kohler & 31HP Briggs & Stratton Units: 51.2 inches (130.0 cm)
- 23HP Kohler Units: 54.1 in (137.4 cm)

Minimum Turning Radius

- 27HP Kohler & 31HP Briggs & Stratton Units: 55.25 inches (140.3 cm)
- 23HP Kohler Units: 56.3 in (143.0 cm)

Curb Weight:

Without deck	911 lb (413 kg)
52 inch Deck	1303 lb (591 kg)
60 inch Deck	1348 lb (611 kg)
72 inch Deck	1397 lb (634 kg)

Torque Requirements

Bolt Location	Torque
Engine Mounting Bolts	30-35 ft-lb (41-47 N-m)
Wheel Lug Nuts	90-95 ft-lb (122-129 N-m)
Wheel Motor Mounting Bolts	72-77 ft-lb (98-104 N-m)
Wheel Hub Lock Nut	210-250 ft-lb (285-339 N-m)
Rollover Protection System (Roll Bar) Mounting Bolts	30-35 ft-lb (41-47 N-m)
Clutch Retaining Bolt (secured with threadlocker)	55-60 ft-lb (75-81 N-m)

Product Overview

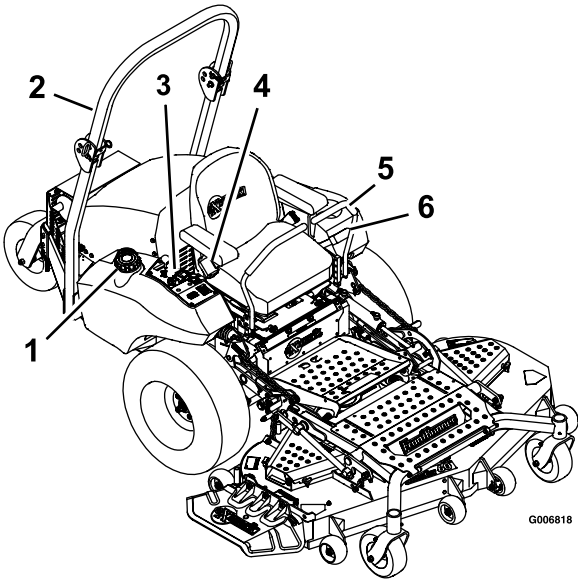

Figure 4

- 1. Fuel Cap
- 2. Roll Bar
- 3. Controls
- 4. Seat Belt
- 5. Motion Control Lever
- 6. Parking Brake Lever

Operation

Note: Determine the left and right sides of the machine from the normal operating position.

Controls

Motion Control Levers

The motion control levers located on each side of the console control the forward and reverse motion of the machine. The levers control the flow of hydraulic oil from the hydrostatic pump to the drive wheel motor for each side.

Moving the levers forward or backward turns the wheel on the same side forward or in reverse. Wheel speed is proportional to the amount the lever is moved.

Moving the levers outward from the center position into the T-slot locks them in the neutral position (Figure 6).

Choke Control

Located on right fuel tank console.

The choke is used to aid in starting a cold engine. Moving the choke lever forward will put the choke in the “ON” position and moving the choke lever to the rear, to the detent, will put the choke in the “OFF” position. Do Not run a warm engine with choke in the “ON” position.

Throttle Control

Located on right fuel tank console.

The throttle is used to control engine speed. Moving the throttle lever forward will increase engine speed and moving the throttle lever to the rear will decrease engine speed. Moving the throttle forward into the detent is full throttle.

Park Brake Lever

Located on left side of unit, between the seat and the dummy tank.

The brake lever engages a parking brake on the drive wheels.

Pull the lever up and rearward to engage the brake.

Push the lever forward and down to disengage the brake.

The unit must be tied down and brake engaged when transporting.

Ignition Switch

Located on right fuel tank console.

The ignition switch is used to start and stop the engine. The switch has three positions “OFF”, “ON” and “START”. Insert key into switch and rotate clockwise to the “ON” position. Rotate clockwise to the next position to engage the starter (key must be held against spring pressure in this position).

Note: Brake must be engaged, motion control levers out (neutral lock position), and PTO switch “OFF” to start engine. (It is not necessary for the operator to be in the seat to start the engine.)

Hour Meter

Located on the right fuel tank console.

The hour meter is connected to a pressure switch installed in the engine block and it records the number of hours that the engine has run. If the ignition switch is left on without engine running, hour meter will not run.

Note: This switch is not a low oil sensor and will not alert the operator if the engine oil is low.

Fuel Shut-Off Valve

Located in fuel line by fuel tank and fuel filter.

The fuel shut-off valve is used to shut off the fuel when the machine will not be used for a few days, during transport to and from the jobsite, and when parked inside a building.

Rotate the valve 1/4 turn clockwise to shut off fuel. Rotate the valve 1/4 turn counterclockwise to turn on fuel.

Fuel Gauge

Located at the rear of the right fuel tank.

The fuel gauge monitors the amount of fuel in the right fuel tank only. The left tank does not hold fuel.

Drive Wheel Release Valves

Located on the top left front corner of hydrostatic pumps.

Drive wheel release valves are used to release the hydrostatic drive system to allow the machine to be pushed without the engine running.

With a wrench, turn both valves one turn counterclockwise to release drive system. Turn clockwise to reset system. **Do Not overtighten. Do Not tow machine.**

- For 27HP Kohler & 31HP Briggs & Stratton Units: Use a 5/8 inch wrench to turn the valves.
- For 23HP Kohler Units: Use a 7/16 inch wrench to turn the valves.

PTO Engagement Switch

Located on right fuel tank.

Switch must be pulled out to the “ROTATE” position to engage the blades. Switch is pushed in to the “STOP” position to stop the blades.

Hydraulic Lift Switch

Located on right fuel tank console.

The hydraulic lift switch is used to raise and lower the mower deck.

Push the front portion of the hydraulic lift switch down to raise the mower deck to the desired height.

Push the rear portion of the hydraulic lift switch down to lower the mower deck to the desired height.

Pre-Start

Fill fuel tanks. For best results use only clean, fresh regular grade unleaded gasoline with an octane rating of 87 or higher. Regular grade leaded gasoline may also be used; however, combustion chamber and cylinder head will require more frequent service. See Engine Owner’s Manual.

Do Not add oil to gasoline.

Do Not overfill fuel tank. Never fill the fuel tank so that the fuel level rises above a level that is 1/2 inch (13 mm) below the bottom of the filler neck to allow for fuel expansion and prevent fuel spillage.

Make sure you understand the controls, their locations, their functions, and their safety requirements.

Refer to the Maintenance section and perform all the necessary inspection and maintenance steps.

Operating Instructions

Raise the Rollover Protection System (ROPS)

Important: Lower the roll bar only when absolutely necessary.

1. Remove the hairpin cotter pins and remove the two roll bar pins (Figure 5).
2. Raise the roll bar to the upright position and install the two pins and secure them with the hairpin cotter pins (Figure 5).

Important: Always use the seat belt with the roll bar in the raised position. Ensure that the rear part of the seat is secured with the seat latch.

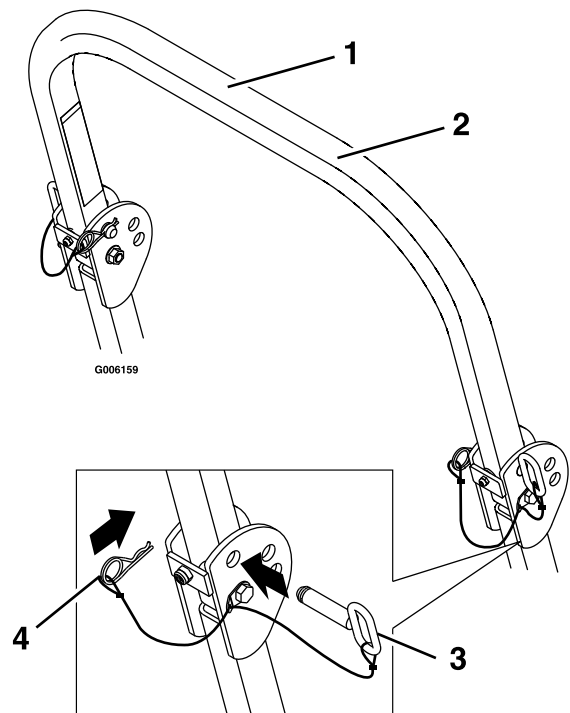

Figure 5

- | | |
|--------------------|-----------------------|
| 1. Roll bar | 3. Pin |
| 2. Raised position | 4. Hairpin cotter pin |

Operation

Open the Fuel Shut-Off Valve

The fuel shut-off valve is located on the right side of unit in fuel line next to the fuel filter. Raise the rear hood to access fuel shut-off valve.

Starting the Engine

1. Move the motion control levers out to the neutral lock position.
2. Pull up and back on the parking brake lever to engage the parking brake.
3. Push in on the PTO switch to the “STOP” position.

Note: It is not necessary for the operator to be in the seat to start the engine.

4. Place the throttle midway between the “SLOW” and “FAST” positions.
5. On a cold engine, push the choke lever forward into the “ON” position.

On a warm engine, leave the choke in the “OFF” position.

6. Turn ignition switch to the “START” position. Release the switch as soon as the engine starts.

Important: Do Not crank the engine continuously for more than ten seconds at a time. If the engine does not start, allow a 60 second cool-down period between starting attempts. Failure to follow these guidelines can burn out the starter motor.

7. If the choke is in the “ON” position, gradually return choke to the “OFF” position as the engine warms up.

Engaging the PTO

⚠ DANGER

The rotating blades under the mower deck are dangerous. Blade contact can cause serious injury or kill you.

Do Not put hands or feet under the mower or mower deck when the blades are engaged.

⚠ DANGER

An uncovered discharge opening will allow objects to be thrown in an operator’s or bystander’s direction. Also, contact with the blade could occur. Thrown objects or blade contact can cause serious injury or death.

Never operate the mower with the discharge deflector raised, removed, or altered unless there is a grass collection system or mulch kit in place and working properly.

The PTO push-pull switch engages the cutting blades. Be sure that all persons are clear of the mower deck and discharge area before engaging PTO.

Important: Operator must be in seat before the PTO can be engaged.

1. Set the throttle to the “MIDWAY” position.
2. Pull the PTO switch outward to the “ROTATE” position.
3. Place the throttle in the “FAST” position to begin mowing.

Disengaging the PTO

1. Set the throttle to the “MIDWAY” position.
2. Push the PTO switch in to the “STOP” position to disengage the blades.

Stopping the Engine

1. Bring the unit to a full stop.
2. Disengage the PTO.
3. Move the motion control levers out to the neutral lock position.
4. Engage the parking brake.
5. Place the throttle midway between the “SLOW” and “FAST” positions.
6. Allow the engine to run for a minimum of 15 seconds, then turn the ignition switch to the “OFF” position to stop the engine.
7. Remove the key to prevent children or other unauthorized persons from starting engine.
8. Close the fuel shut-off valve when the machine will not be in use for a few days, when transporting, or when the unit is parked inside a building.

Driving the Machine

⚠ CAUTION

Machine can spin very rapidly by positioning one lever too much ahead of the other. Operator may lose control of the machine, which may cause damage to the machine or injury.

- Use caution when making turns.
- Slow the machine down before making sharp turns.

Important: To begin movement (forward or backward) the operator must be in the seat, the brake lever must be disengaged (pushed down) before the motion control levers can be moved in or the engine will stop.

When levers are centered in the T-slot the drive system is in the neutral position. With levers moved out in the T-slot the drive system is in the neutral lock position (Figure 6).

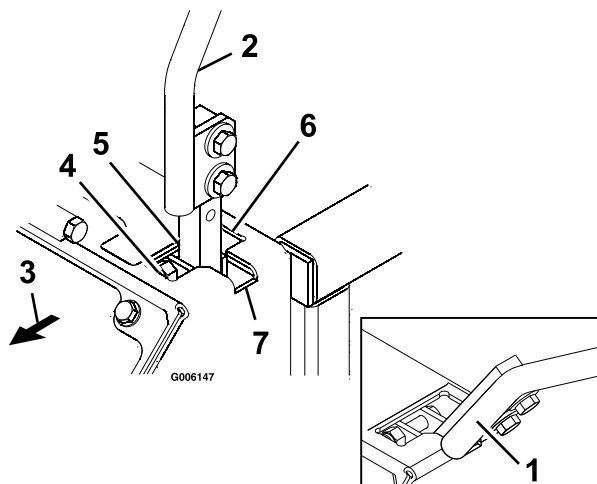

Figure 6

- | | |
|-------------------------------|-----------------|
| 1. Handles Out (Neutral Lock) | 5. Neutral |
| 2. Handles In (Neutral) | 6. Reverse |
| 3. Front of Unit | 7. Neutral Lock |
| 4. Forward | |

Driving Forward

1. Release the parking brake.
2. Move the motion control levers inward to the center to the neutral unlocked position.

3. To move forward in a straight line apply equal forward pressure to both levers.

To turn left or right, pull the motion control lever back toward neutral in the direction desired.

The machine will move faster the farther the motion control levers are moved away from neutral.

4. To stop, pull the motion control levers back to the neutral position.

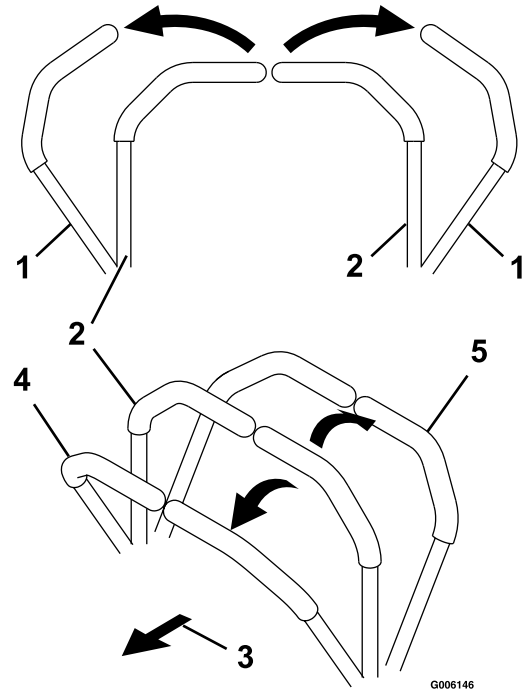

Figure 7

- | | |
|-------------------------------|------------|
| 1. Handles Out (Neutral Lock) | 4. Forward |
| 2. Handles In (Neutral) | 5. Reverse |
| 3. Front of Unit | |

Driving in Reverse

1. Move the motion control levers inward to the center to the neutral unlocked position.
2. To move rearward in a straight line applying equal pressure pull both motion control levers rearward. To turn left or right, release pressure on the motion control lever toward the direction desired.
3. To stop, push the motion control levers to the neutral position.

Transporting

Transporting a Unit

Important: Do Not transport FrontRunner tractor without an approved Exmark front mount attachment.

Use a heavy-duty trailer or truck to transport the machine. Lock brake and block wheels. Securely fasten the machine to the trailer or truck with straps, chains, cable, or ropes. Be sure that the trailer or truck has all necessary lighting and marking as required by law. Secure a trailer with a safety chain.

CAUTION

This unit does not have proper turn signals, lights, reflective markings, or a slow moving vehicle emblem. Driving on a street or roadway without such equipment is dangerous and can lead to accidents causing personal injury. Driving on a street or roadway without such equipment may also be a violation of State laws and the operator may be subject to traffic tickets and/or fines.

Do Not drive a unit on a public street or roadway.

WARNING

Loading a unit on a trailer or truck increases the possibility of tip-over. Tip-over could cause serious injury or death.

- Use extreme caution when operating a unit on a ramp.
- Use only a single, full width ramp; Do Not use individual ramps for each side of the unit.
- If individual ramps must be used, use enough ramps to create an unbroken ramp surface wider than the unit.
- Do Not exceed a 15° angle between ramp and ground or between ramp and trailer or truck.
- Avoid sudden acceleration while driving unit on a ramp.

Loading a Unit

Use extreme caution when loading units on trailers or trucks. One full width ramp is required. If it is not possible to use one full width ramp, use enough individual ramps to simulate a full width continuous ramp.

Ramp should be long enough so that the angles between the ramp and the ground and the ramp and the trailer or truck do not exceed 15°. A steeper angle may cause mower deck components to get caught as the unit moves from ramp to trailer or truck. Steeper angles may also cause the unit to tip. If loading on or near a slope, position the trailer or truck so it is on the down side of the slope and the ramp extends up the slope. This will minimize the ramp angle. The trailer or truck should be as level as possible.

Important: Do Not attempt to turn the unit while on the ramp, you may lose control and drive off the side.

Avoid sudden acceleration when driving on a ramp.

Maintenance

Note: Determine the left and right sides of the machine from the normal operating position.

⚠ WARNING

While maintenance or adjustments are being made, someone could start the engine. Accidental starting of the engine could seriously injure you or other bystanders.

Remove the key from the ignition switch, engage parking brake, and pull the wire(s) off the spark plug(s) before you do any maintenance. Also push the wire(s) aside so it does not accidentally contact the spark plug(s).

⚠ WARNING

The engine can become very hot. Touching a hot engine can cause severe burns.

Allow the engine to cool completely before service or making repairs around the engine area.

Recommended Maintenance Schedule(s)

Maintenance Service Interval	Maintenance Procedure
After the first 5 hours	<ul style="list-style-type: none"> • Change the engine oil.
After the first 100 hours	<ul style="list-style-type: none"> • Check the wheel hub locknuts torque specification.
After the first 250 hours	<ul style="list-style-type: none"> • Change the hydraulic filter.
Before each use or daily	<ul style="list-style-type: none"> • Check the engine oil level. • Check the safety interlock system. • Check the rollover protections systems (roll bar) pins. • Check the seat belt. • Check for loose hardware. • Clean the engine cooling system. • Remove accumulated debris from engine.
Every 40 hours	<ul style="list-style-type: none"> • Check the hydraulic oil level. • Check the tire pressures. • Check the condition of the belts. • Grease hitch and cylinder pivots. • Grease the dual tail wheel pivot (if applicable).
Every 50 hours	<ul style="list-style-type: none"> • Service the air cleaner. (May need more often under severe conditions. See the Engine Owner's Manual for additional information.)
Every 80 hours	<ul style="list-style-type: none"> • Remove the engine shrouds and clean the cooling fins.
Every 100 hours	<ul style="list-style-type: none"> • Change the engine oil. (May need more often under severe conditions.) • Grease the fold pivot pin.
Every 160 hours	<ul style="list-style-type: none"> • Lubricate the brake handle pivot. • Lubricate the brake rod bushings. • Lubricate the motion control bronze bushings. • Lubricate the steering linkage rod ends. • Check the spark plugs.
Every 500 hours	<ul style="list-style-type: none"> • Check the wheel hub locknuts torque specification.

Maintenance

Maintenance Service Interval	Maintenance Procedure
Monthly	<ul style="list-style-type: none"> • Check the battery charge.
Yearly	<ul style="list-style-type: none"> • Grease the fold lock pin. • Grease the rear caster pivot. • Grease the belt idlers. • Grease the motion control pivots. • Grease the transfer spring ends. • Lubricate the caster wheel hub(s). • Lubricate the motion control shaft. • Change the hydraulic filter.

Periodic Maintenance

Check Engine Oil Level

Service Interval: Before each use or daily

1. Stop engine and wait for all moving parts to stop. Make sure unit is on a level surface.
2. Tilt seat forward and raise hood to gain access to access to engine area.
3. Check with engine cold.
4. Clean area around dipstick. Remove dipstick and wipe oil off. Reinsert the dipstick and push it all the way down into the tube. Remove the dipstick and read the oil level.
5. If the oil level is low, wipe off the area around the oil fill cap, remove cap and fill to the “FULL” mark on the dipstick. Use oil as specified in Engine Owner’s Manual. **Do Not** overfill.

Important: Do Not operate the engine with the oil level below the “LOW” (or “ADD”) mark on the dipstick, or over the “FULL” mark.

Check Battery Charge

Service Interval: Monthly

Allowing batteries to stand for an extended period of time without recharging them will result in reduced performance and service life. To preserve optimum battery performance and life, recharge batteries in storage when the open circuit voltage drops to 12.4 volts.

Note: To prevent damage due to freezing, battery should be fully charged before putting away for winter storage.

Check the voltage of the battery with a digital voltmeter. Locate the voltage reading of the battery in the table and charge the battery for the recommended time interval to bring the charge up to a full charge of 12.6 volts or greater.

Important: Make sure the negative battery cables are disconnected and the battery charger used for charging the battery has an output of 16 volts and 7 amps or less to avoid damaging the battery (see chart for recommended charger settings).

⚠ WARNING

CALIFORNIA Proposition 65 Warning

Battery posts, terminals, and related accessories contain lead and lead compounds, chemicals known to the State of California to cause cancer and reproductive harm. Wash hands after handling.

Voltage Reading	Percent Charge	Maximum Charger Settings	Charging Interval
12.6 or greater	100%	16 volts/7 amps	No Charging Required
12.4 – 12.6	75–100%	16 volts/7 amps	30 Minutes
12.2 – 12.4	50–75%	16 volts/7 amps	1 Hour
12.0–12.2	25–50%	14.4 volts/4 amps	2 Hours
11.7–12.0	0–25%	14.4 volts/4 amps	3 Hours
11.7 or less	0%	14.4 volts/2 amps	6 Hours or More

Check Safety Interlock System

Service Interval: Before each use or daily

Note: To prevent engine cut-outs on rough terrain the seat kill switch has a 1/2 second delay.

1. Check starting circuit. Starter **should** crank with, parking brake **engaged**, PTO **disengaged** and motion control levers moved out in the **neutral lock** position. The operator does not need to be in the seat to start the engine.

Try to start with **operator in seat**, parking brake disengaged, PTO disengaged and motion control levers in the **neutral lock** position - starter **must not crank**.

Try to start with **operator in seat**, parking brake engaged, PTO **engaged** and motion control levers in the **neutral lock** position - starter **must not crank**.

Try to start with **operator in seat**, parking brake **engaged**, PTO **disengaged**, and the **left motion control lever in**, starter **must not crank**, repeat again with the **right lever in**, then with **both levers in** - starter **must not crank**.

2. Check the kill circuits. Run engine at one-third throttle, **disengage** parking brake and **raise off** of seat (but do not get off of machine) engine **must initiate shutdown** after approximately 1/2 second has elapsed (seat has time delay kill switch to prevent cut-outs on rough terrain).

Run engine at one-third throttle, **engage PTO** and **raise off** of seat (but do not get off of machine) engine **must initiate shutdown** after 1/2 second has elapsed.

Run engine at one-third throttle, with brake disengaged, move levers in and raise off seat (but do not get off of machine) engine **must initiate shutdown** after 1/2 second has elapsed.

Again, run engine at one-third throttle, brake **engaged**, and move **left motion control lever in** - engine **must initiate shutdown**.

Repeat again moving the **right lever in**, then moving **both levers in** - engine **must initiate shutdown** whether operator is **on seat or not**.

3. Check the PTO circuit. See the FR524, FR604, and FR724 Operator's manual to become familiar with the deck operation. Open the folding deck latches, **disengage** the park brake, move the motion control levers in to **neutral**, and **disengage** the PTO. **Lower** the deck until the PTO switch arm is no longer depressing the PTO "kill" switch (see Figure 8).

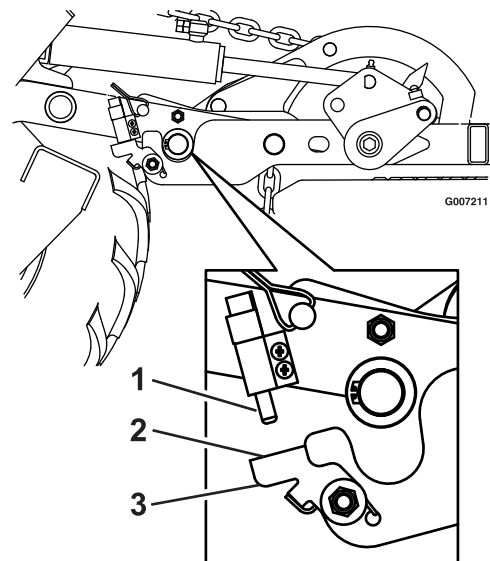

Figure 8

Left Side—Inside of Hitch Shown

1. PTO "Kill" Switch
2. PTO Switch Arm
3. Lower deck until arm Does Not contact the switch.

Run the engine at half throttle and **pull up** on the PTO engagement switch.

The **PTO must not engage**.

Maintenance

Note: If machine does not pass any of these tests, Do Not operate. Contact your authorized **EXMARK SERVICE DEALER**.

Important: It is essential that operator safety mechanisms be connected and in proper operating condition prior to use for mowing.

Check Rollover Protections Systems (Roll Bar) Pins

Service Interval: Before each use or daily

Make sure latch pin and hair pin are fully installed and lanyard is in good condition.

Check Seat Belt

Service Interval: Before each use or daily

Visually inspect seat belt for wear, cuts, and proper operation of retractor and buckle. Replace before operating if damaged.

Check for Loose Hardware

Service Interval: Before each use or daily

1. Stop engine, wait for all moving parts to stop, and remove key. Engage parking brake.
2. Visually inspect machine for any loose hardware or any other possible problem. Tighten hardware or correct the problem before operating.

Service Air Cleaner

Service Interval: Every 50 hours (May need more often under severe conditions. See the Engine Owner's Manual for additional information.)

1. Stop engine, wait for all moving parts to stop, and remove key. Engage parking brake.
2. Tilt seat forward and raise hood to gain access to the air cleaner.
 - For 27HP Kohler & 31HP Briggs & Stratton Units:
 - A. Loosen retaining clips and remove air cleaner compartment cover.

- B. Remove paper element. Check the condition of the paper element. Replace if dirty, bent or damaged.
 - C. Check the condition of the inner element. Replace whenever it appears dirty, typically every other time the paper element is replaced. Clean the base around the inner element before removing, so dirt does not get into the engine.
 - D. **Do Not** wash or use pressurized air to clean paper element or inner element.
 - E. Reinstall elements. Position the cover so that the rubber dust ejector is pointing downward and secure with retaining clips.
- For 23 HP Kohler Units:
 - A. Remove foam pre-cleaner element and wash in warm water with detergent. Rinse until all traces of detergent are eliminated and squeeze out excess water (**Do Not wring**). Air dry. Saturate with engine oil and squeeze out excess oil.
 - B. Check paper element. **Do Not** wash or use pressurized air to clean paper element. Replace if dirty, bent or damaged.
 - C. Reinstall foam pre-cleaner to paper element, then reinstall paper element and cover.

Change Engine Oil

Service Interval: After the first 5 hours

Every 100 hours/Yearly (whichever comes first) (May need more often under severe conditions.)

1. Stop engine, wait for all moving parts to stop, and remove key. Engage parking brake.
2. Tilt seat forward and raise hood to gain access to the engine area.
3. Drain oil while engine is warm from operation.
4. Fit hose in literature pack over oil drain valve. Rotate the valve 1/4 counterclockwise and gently pull outward to open the valve. Allow the oil to drain, then close the valve by pushing inward and rotating 1/4 turn clockwise. Remove and retain the hose for future use.

5. Replace the oil filter every other oil change. Clean around oil filter and unscrew filter to remove. Before reinstalling new filter, apply a thin coating of oil on the surface of the rubber seal. Turn filter clockwise until rubber seal contacts the filter adapter then tighten filter an additional 2/3 to 3/4 turn.
6. Clean around oil fill cap and remove cap. Fill to specified capacity and replace cap.
7. Use oil recommended in engine owner's manual. **Do Not** overfill. Start the engine and check for leaks.

Check Hydraulic Oil Level

Service Interval: Every 40 hours

1. Stop engine and wait for all moving parts to stop. Engage parking brake.
2. Tilt seat up.
3. Clean area around hydraulic reservoir cap and remove cap. Oil level should be to the top of the baffle inside the tank. If not, add oil. Use only Mobil 1 15W-50 synthetic motor oil. Replace hydraulic reservoir cap and tighten until snug. Do Not overtighten.

Note: The baffle is labeled "HOT" and "COLD". The oil level varies with the temperature of the oil. The "HOT" level shows the level of oil when it is at 225°F (107°C). The "COLD" level shows the level of the oil when it is at 75°F (24°C). Fill to the appropriate level depending upon the temperature of the oil. For example: If the oil is about 150°F (65°C), fill to halfway between the "HOT" and "COLD" levels. If the oil is at room temperature (about 75°F (24°C)), fill only to the "COLD" level.

Check Auxiliary Hydraulic Oil Level

Service Interval: As required

Note: Check the auxiliary hydraulic oil level if there is evidence of a leak or the hydraulic cylinder does not perform normally.

1. Retract the hydraulic cylinder.
2. Stop engine and wait for all moving parts to stop.

3. Tilt the seat forward.
4. Locate the auxiliary hydraulic power unit reservoir (see Figure 9).

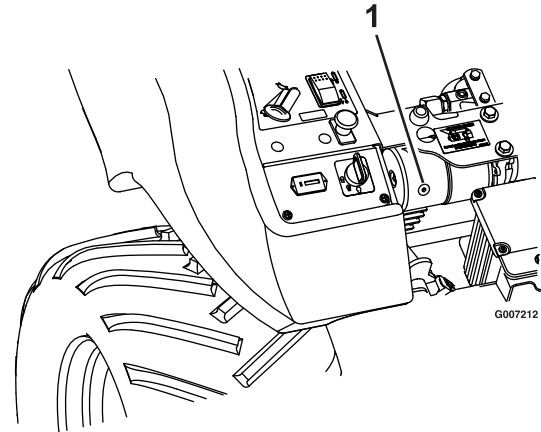

Figure 9

1. Auxiliary hydraulic reservoir plug
5. Clean area around the reservoir plug and remove. Oil level should be up to the reservoir plug hole. If not, add oil. Use only Mobil 1 15W-50 synthetic motor oil. Replace reservoir plug and tighten until snug. Do Not overtighten.

Check Tire Pressures

Service Interval: Every 40 hours

1. Stop engine, wait for all moving parts to stop, and remove key. Engage parking brake.
2. Check tire pressure in drive tires.
 - For 23HP Kohler Units: The drive tires should be inflated to 13 psi (90 kpa).
 - For 27HP Kohler & 31HP Briggs & Stratton Units: The drive tires should be inflated to 9 psi (62 kpa).
3. The rear caster tire(s) is semi-pneumatic and does not need to be inflated.

Note: Do Not add any type of tire liner or foam fill material to the tires. Excessive loads created by foam filled tires may cause failures to the hydro drive system, frame, and other components. Foam filling tires will void the warranty.

Check Condition Of Belts

Service Interval: Every 40 hours

1. Stop engine, wait for all moving parts to stop, and remove key. Engage parking brake.
2. Check pump and PTO drive belts.
3. Belts are spring tensioned and no adjustment is necessary. See **Pump Drive Belt Tension and Replacement** sections in Adjustments.

Lubricate Grease Fittings

Note: See chart for service intervals.

1. Stop engine, wait for all moving parts to stop, and remove key. Engage parking brake.
2. Lubricate fittings with one to two pumps of NGLI grade #2 multi-purpose gun grease.

Refer to the following chart for fitting locations and lubrication schedule.

Lubrication Chart			
Fitting Locations	Initial Pumps	Number of Places	Service Interval
1. Hitch and Cylinder Pivots	2	4	40 Hours
2. Fold Pivot Pin	2	2	100 Hours
3. Fold Lock Pin	2	2	Yearly
4. Rear Caster Pivot	*0	1	*Yearly
5. Belt Idlers	1	2	Yearly
6. Motion Control Pivots	1	2	Yearly
7. Transfer Spring Ends	1	4	Yearly
8. Dual Tail Wheel Pivot (if applicable)	2	1	40 Hours

* See step 3 for special lubrication instructions on the rear caster pivots and the **Lubricate Rear Caster Wheel Hub** section for special lubrication instructions on the rear casters wheel hub.

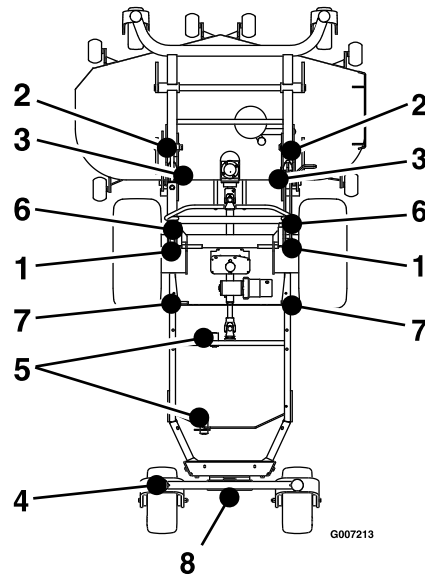

3. Lubricate front caster pivots once a year. Remove hex plug and cap. Thread grease zerk in hole and pump with grease until it oozes out around top bearing. Remove grease zerk and thread plug back in. Place cap back on.

Lubricate Rear Caster Wheel Hub(s)

Service Interval: Yearly

1. Stop engine, wait for all moving parts to stop, and remove key. Engage parking brake.

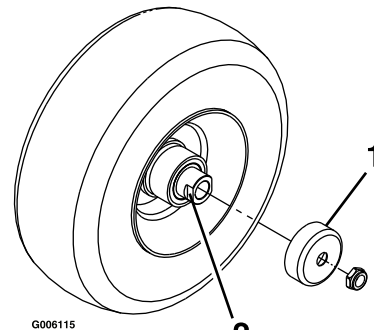

Figure 10

1. Seal guard
 2. Spacer nut with wrench flats
2. Remove caster wheel from caster forks.
 3. Remove seal guards from the wheel hub.
 4. Remove one of the spacer nuts from the axle assembly in the caster wheel. Note that thread locking adhesive has been applied to lock the

spacer nuts to the axle. Remove the axle (with the other spacer nut still assembled to it) from the wheel assembly.

5. Pry out seals, and inspect bearings for wear or damage and replace if necessary.
6. Pack the bearings with a NGLI grade #1 multi-purpose grease.
7. Insert one bearing, one new seal into the wheel.
Note: Seals (Exmark P/N 103-0063) must be replaced.
8. If the axle assembly has had both spacer nuts removed (or broken loose), apply a thread locking adhesive to one spacer nut and thread onto the axle with the wrench flats facing outward. Do Not thread spacer nut all of the way onto the end of the axle. Leave approximately 1/8 inch (3 mm) from the outer surface of the spacer nut to the end of the axle inside the nut.
9. Insert the assembled nut and axle into the wheel on the side of the wheel with the new seal and bearing.
10. With the open end of the wheel facing up, fill the area inside the wheel around the axle full of NGLI grade #1 multi-purpose grease.
11. Insert the second bearing and new seal into the wheel.
12. Apply a thread locking adhesive to the 2nd spacer nut and thread onto the axle with the wrench flats facing outward.
13. Torque the nut to 75-80 in-lb (8-9 N-m), loosen, then re-torque to 20-25 in-lb (2-3 N-m). Make sure axle does not extend beyond either nut.
14. Reinstall the seal guards over the wheel hub and insert wheel into caster fork. Reinstall caster bolt and tighten nut fully.

Important: To prevent seal and bearing damage, check the bearing adjustment often. Spin the caster tire. The tire should not spin freely (more than 1 or 2 revolutions) or have any side play. If the wheel spins freely, adjust torque on spacer nut until there is a slight amount of drag. Reapply thread locking adhesive.

Lubricate Brake Handle Pivot

Service Interval: Every 160 hours

1. Stop engine, wait for all moving parts to stop, and remove key. Engage parking brake.

2. Tilt seat forward.
3. Lubricate bronze bushings on brake handle pivot with a spray type lubricant or light oil.

Lubricate Brake Rod Bushings

Service Interval: Every 160 hours

1. Stop engine, wait for all moving parts to stop, and remove key. Engage parking brake.
2. Tilt seat forward and raise hood.
3. Lubricate bronze bushings on each end of the brake rod shaft with a spray type lubricant or light oil (bushings are located to the inside of the flange bearings).

Lubricate Motion Control Bronze Bushings

Service Interval: Every 160 hours

1. Stop engine, wait for all moving parts to stop, and remove key. Engage parking brake.
2. Unhook seat latch and tilt seat up.
3. Lubricate bronze bushings on flange bearings securing the motion control arm shafts with a light oil or a spray type lubricant.

Lubricate Motion Control Shaft

Service Interval: Yearly

1. Stop engine, wait for all moving parts to stop, and remove key. Engage parking brake.
2. Tilt seat forward.
3. Remove tab at rear of motion control shaft.
4. Pull motion control shaft out and lubricate with an NGLI grade #2 multi-purpose gun grease.
5. Re-install shaft and tab.

Lubricate Steering Linkage Rod Ends

Service Interval: Every 160 hours

1. Stop engine, wait for all moving parts to stop, and remove key. Engage parking brake.

Maintenance

2. Tilt seat forward.
3. Lubricate each end of both steering linkage rods with a spray lubricant or light oil

Check Spark Plugs

Service Interval: Every 160 hours

Remove spark plugs, check condition and reset gaps, or replace with new plugs. See Engine Owner's Manual.

Change Fuel Filter

Service Interval: As required

A fuel filter is installed between the fuel tanks and the engine. Replace when necessary.

Replacement Filters	
Kohler	Kohler P/N 2405010–15 Micron
Briggs & Stratton	Briggs & Stratton P/N 695327– 30 Micron

Change Hydraulic System Filter

**Service Interval: After the first 250 hours
Yearly thereafter**

Note: Use only Exmark Part No. 103-2146.

1. Stop engine, wait for all moving parts to stop, and remove key. Engage parking brake.
2. Carefully clean area around filter. It is important that no dirt or contamination enter hydraulic system.
3. Unscrew filter to remove and allow oil to drain from reservoir.

Important: Before reinstalling new filter, fill it with Mobil 1 15W-50 and apply a thin coat of oil on the surface of the rubber seal.

Turn filter clockwise until rubber seal contacts the filter adapter, then tighten the filter an additional 2/3 to 3/4 turn.

4. Fill reservoir as stated in **Check Hydraulic Oil Level** section.
5. Raise the rear of machine up and support with jack stands (or equivalent support) just high enough to allow drive wheels to turn freely.

⚠ CAUTION

Raising the mower for service or maintenance relying solely on mechanical or hydraulic jacks could be dangerous. The mechanical or hydraulic jacks may not be enough support or may malfunction allowing the unit to fall, which could cause injury.

Do Not rely solely on mechanical or hydraulic jacks for support. Use adequate jack stands or equivalent support

6. Start engine and move throttle control ahead to full throttle position. Move the speed control levers to the full speed and run for several minutes. Shut down machine and recheck oil level.

Note: Do Not change hydraulic system oil (except for what can be drained when changing filter), unless it is felt the oil has been contaminated or been extremely hot.

Changing oil unnecessarily could damage hydraulic system by introducing contaminants into the system.

Check Wheel Hub Locknuts

**Service Interval: After the first 100 hours
Every 500 hours thereafter**

When tightening the lock nut on the wheel motor tapered shaft:

Torque to 210-250 ft-lb (285-339 N-m).

Note: Do Not use antiseize on wheel hub.

Fuel Tank — Mounting Hardware Specifications

Service Interval: As required

When installing the nuts on the fuel tank studs, fully tighten the nyloc nut and back off 1/2 turn. This allows for normal fuel tank expansion and contraction with changes in temperature and fuel levels.

Thread Locking Adhesives

Thread locking adhesives such as “Loctite 242” or “Fel-Pro, Pro-Lock Nut Type” are used on the following fasteners:

- Pump drive sheave set screws.
- Line shaft sheave setscrews.
- Square head setscrews on Hydro pump control arms.
- Sheave retaining bolt in the end of engine crankshaft.
- Caster wheel spacer nuts.
- Fuel tank bulkhead fitting nuts.
- Motion control tab retaining bolt.

Adhesives such as “Loctite RC/609 or RC/680” or “Fel-Pro Pro-Lock Retaining I or Retaining II” are used on the following:

Fuel tank studs, where studs are inserted into tank.

Dielectric Grease

Dielectric grease is used on all blade type electrical connections to prevent corrosion and loss of contact.

Adjustments

Note: Disengage PTO, shut off engine, wait for all moving parts to stop, engage parking brake, and remove key before servicing, cleaning, or making any adjustments to the unit.

Pump Drive Belt Tension

Self-tensioning - No adjustment necessary.

Pump Drive Belt Replacement

1. Stop engine, wait for all moving parts to stop, and remove key. Engage parking brake.
2. Remove pump drive belt.
3. Route new belt onto sheaves as shown in the decal located on the right hand side of the left hood support (see Figure 11).

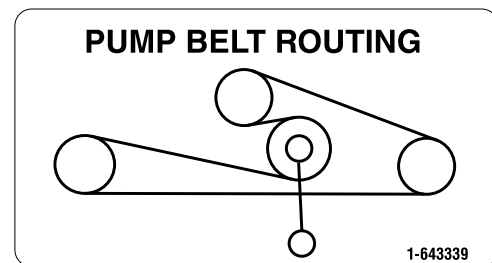

Figure 11

Park Brake Adjustment

Check to make sure brake is adjusted properly.

1. Stop engine, wait for all moving parts to stop, and remove key. Engage parking brake.
2. Tilt seat forward and raise hood.
3. Pull the brake lever up into the engaged position.
4. Locate the park brake spring assembly (see Figure 12). There should be a gap of 1/8 inch (3 mm) between the yoke and thin nyloc nut on the brake bolt. If necessary, rotate the thin nyloc nut to obtain the 1/8 inch gap.

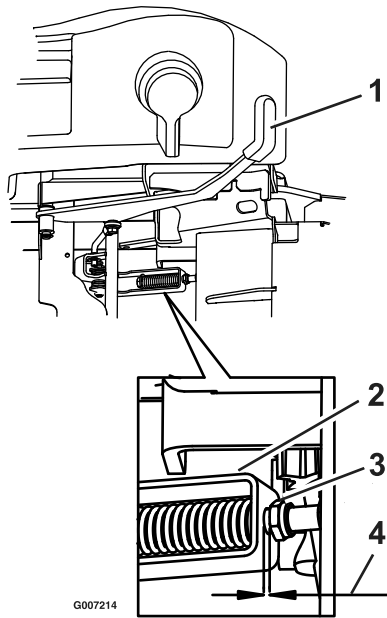

Figure 12

- | | |
|-----------------------|--|
| 1. Park brake engaged | 3. Thin nyloc nut |
| 2. Yoke | 4. 1/8 inch (3 mm) gap between nut and yoke. |

- If park brake does not fully disengage when the lever is disengaged check the brake rod linkage assembly. The assembly should measure 7 3/8 inch (18.7 cm) from the center of the ball joint to the center of the lower end of the linkage rod (see Figure 13).

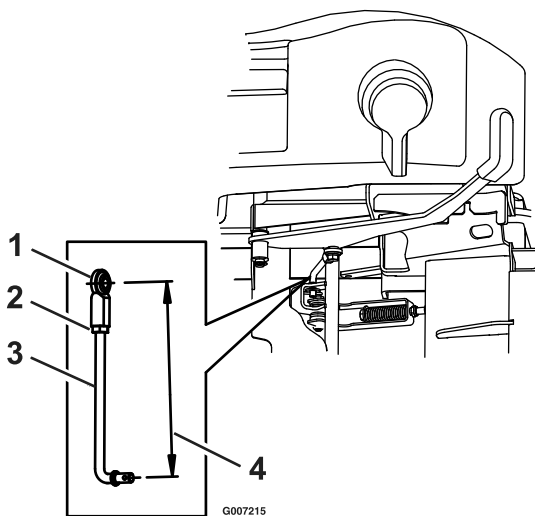

Figure 13

- | | |
|---------------|---------------------------|
| 1. Ball joint | 3. Park brake linkage rod |
| 2. Jam nut | 4. 7 3/8 inch (18.7 cm) |

- If the linkage does not measure 7 3/8 inch (18.7 cm) or still does not disengage as desired,

remove the bolt that secures the ball joint to the brake lever and loosen the jam nut next to the ball joint. Rotate the ball joint in half-turns counterclockwise until desired disengagement is obtained.

Motion Control Linkage Adjustment

⚠ WARNING

Engine must be running and drive wheels must be turning so motion control adjustment can be performed. Contact with moving parts or hot surfaces may cause personal injury

Keep fingers, hands, and clothing clear of rotating components and hot surfaces.

- This adjustment must be made with the drive wheels turning. First raise the frame and block up so that drive wheels can rotate freely.
- Remove the electrical connection from the seat safety switch, located directly in front of the seat switch assembly.
- Temporarily** install a jumper wire across the terminals in the connector of the main wiring harness.
- Start the engine.
- Run the unit at least 5 minutes with the drive levers at full forward speed to bring hydraulic system oil up to operating temperature.
- To obtain the neutral position, adjust the left and right pump control rod linkages that connect the steering control to the pump control arms until the wheels stop, or creep slightly in reverse.
- To adjust each linkage, loosen the jam nut next the ball joint at the upper end of the linkage rod assembly. Then rotate the assembly using a wrench to turn the double nuts on the assembly (see Figure 14).
- Re-tighten the jam nut against the ball joint on each side.

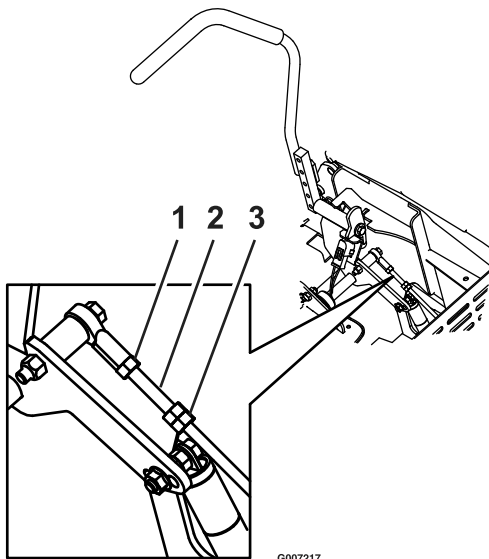

Figure 14

1. Loosen jam nut
2. Pump control rod linkage
3. Use wrench to turn double nuts

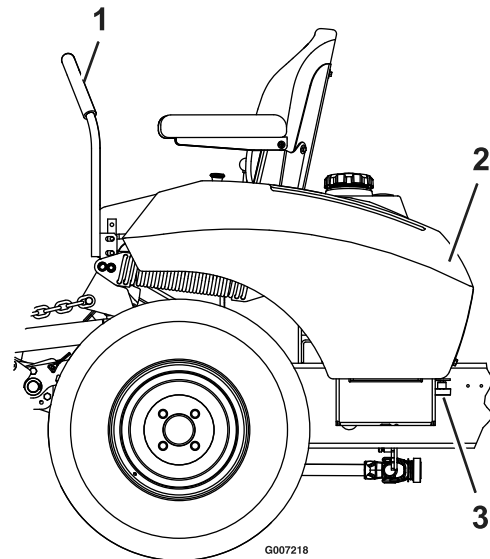

Figure 15

1. Motion control lever
2. Left fender
3. Fender knob

9. Move the motion control levers to the reverse position. Return the motion control levers to neutral. The wheels must stop turning (or slightly creep in reverse).
10. Stop engine and wait for all moving parts to stop. Remove jumper wire from wire harness connector and plug connector into seat switch.
11. Lower from jackstands.

Weight Transfer Spring Adjustment

Weight transfer springs are assembled from the factory to apply the maximum amount of weight onto the drive wheels. This setting provides the greatest amount of traction. Some conditions may require the rear wheel lift to be reduced. This can be done by reducing the amount to weight transfer, which will increase the amount of weight on the front and rear casters.

1. Rotate the left motion control arm up and into the operation position.
2. Locate and loosen the knob under the rear of the left fender (see Figure 15).

3. Slide the fender forward and twist upward and outward to remove.
4. To adjust the weight transfer springs, fold the mower deck and front frame and lock in service position. See Deck Manual for complete instructions.

⚠ WARNING

Weight transfer springs may have stored energy. Removing the weight transfer springs without releasing the stored energy can cause serious injury.

Fold mower deck and front frame and lock in service position to remove spring tension and release stored energy before performing any maintenance or adjustments on the weight transfer springs. (See Deck Manual for Deck Raising instructions).

5. Remove the retaining ring and washer at either end of the weight transfer spring that retains it to the transfer bellcrank pins and/or weight transfer spring anchor pins (see Figure 16).
6. Pull the spring off of front or rear pin and re-install in the outer hole, to reduce the spring force. Re-install the washer and retaining ring.

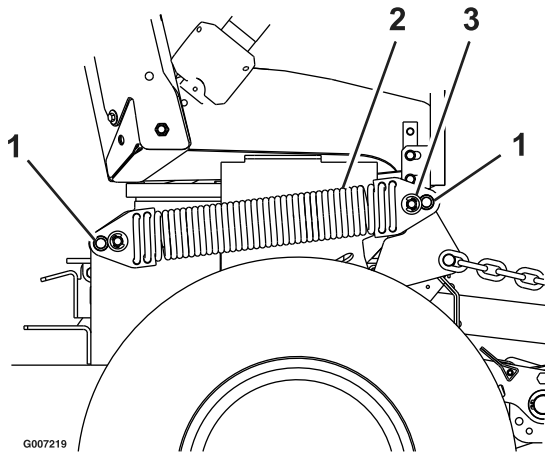

Figure 16
Right-Hand Side of Unit Shown

1. Re-install spring in outer holes to reduce spring tension.
2. Weight transfer spring.
3. Remove e-ring and washer.

7. Re-install the left fender
8. For additional weight transfer adjustment, repeat steps 4 through 7 on the right side of the unit.

Caster Pivot Bearings Pre-Load Adjustment

Remove dust cap from caster and tighten nyloc nut until washers are flat and back off 1/4 of a turn to properly set the pre-load on the bearings. If disassembled, make sure the spring disc washers are reinstalled as shown in Figure 17.

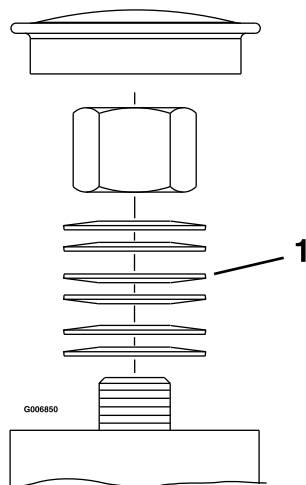

Figure 17

1. Spring disc washers

Cleaning

Clean Engine Cooling System

Service Interval: Before each use or daily (May be required more often in dry or dirty conditions.)

⚠ CAUTION

Excessive debris around the engine cooling air intake and inside of the pump drive belt compartment and damaged or missing rubber baffles can cause the engine and hydraulic system to overheat which can create a fire hazard.

Clean all debris from inside of pump drive belt compartment daily.

1. Stop engine, wait for all moving parts to stop, and remove key. Engage parking brake.
2. Clean all debris from rotating engine air intake screen and from around engine shrouding.
3. Clean all debris from around the engine and drive belts.

Remove Accumulated Debris from Engine (Briggs & Stratton Units Only)

Service Interval: Before each use or daily

Engine parts should be kept clean to reduce the risk of overheating and ignition of accumulated debris.

1. Stop engine, wait for all moving parts to stop, and remove key. Engage parking brake.
2. Remove front panel from engine and clean around the intake manifold, fuel pump, and carburetor.
3. Reinstall the front panel.

Important: Do Not use water to clean engine. Use low pressure compressed air. See Engine Owner's Manual.

Remove Engine Shrouds and Clean Cooling Fins

Service Interval: Every 80 hours

1. Stop engine, wait for all moving parts to stop, and remove key. Engage parking brake.
2. Remove cooling shroud clean-out covers from engine and clean cooling fins. Also clean dust, dirt, and oil from external surfaces of engine, which can cause improper cooling.
3. Make sure cooling shroud clean-out covers are reinstalled. Operating the engine without cooling shroud clean-out covers will cause engine damage due to overheating.

Waste Disposal

Motor Oil Disposal

Engine oil and hydraulic oil are both pollutants to the environment. Dispose of used oil at a certified recycling center or according to your state and local regulations.

Battery Disposal

⚠ DANGER

Battery electrolyte contains sulfuric acid, which is poisonous and can cause severe burns. Swallowing electrolyte can be fatal or if it touches skin can cause severe burns.

- **Wear safety glasses to shield eyes, and rubber gloves to protect skin and clothing when handling electrolyte.**
- **Do Not swallow electrolyte.**

Federal law states that batteries should not be placed in the garbage. Management and disposal practices must be within relevant federal, state, or local laws.

If a battery is being replaced or if the unit containing the battery is no longer operating and is being scrapped, take the battery to a local certified recycling center. If no local recycling is available return the battery to any certified battery reseller.

Troubleshooting

Important: It is essential that all operator safety mechanisms be connected and in proper operating condition prior to mower use.

When a problem occurs, Do Not overlook the simple causes. For example: starting problems could be caused by an empty fuel tank.

The following table lists some of the common causes of trouble. Do Not attempt to service or replace major items or any items that call for special timing of adjustment procedures (such as valves, governor, etc.). Have this work done by your **Engine Service Dealer**.

Note: When disconnecting electrical connectors Do Not pull on the wires to separate the connectors.

Problem	Possible Cause	Corrective Action
Starter does not crank	<ol style="list-style-type: none"> 1. PTO is engaged. 2. Parking brake is not. 3. Drive levers are not in neutral lock position. 4. Battery does not have a full charge. 5. Electrical connections are corroded, loose or faulty. 6. Fuse is blown. 7. Relay or switch is defective. 	<ol style="list-style-type: none"> 1. Disengage the PTO. 2. Set the parking brake. 3. Ensure the drive levers are in the neutral lock position. 4. Charge the battery. 5. Check the electrical connections for good contact. Clean connector terminals thoroughly with electrical contact cleaner, apply dielectric grease and reconnect. 6. Replace the blown fuse. 7. Contact an Authorized Service Dealer.
Engine will not start, starts hard, or fails to keep running	<ol style="list-style-type: none"> 1. Fuel tank is empty. 2. Fuel shutoff valve is closed. 3. Oil level in the crankcase is low. 4. The throttle and choke are not in the correct position. 5. Dirt in fuel filter. 6. Dirt, water, or stale fuel is in the fuel system. 7. Air cleaner is dirty. 8. Electrical connections are corroded, loose or faulty. 9. Relay or switch is defective. 10. Faulty spark plug. 11. Spark plug wire is not connected. 	<ol style="list-style-type: none"> 1. Fill the fuel tank. 2. Open the fuel shutoff valve. 3. Add oil to the crankcase. 4. Be sure the throttle control is midway between the "SLOW" and "FAST" positions, and the choke is in the "ON" position for a cold engine or the "OFF" position for a warm engine. 5. Replace the fuel filter. 6. Contact an Authorized Service Dealer. 7. Clean or replace the air cleaner element. 8. Check the electrical connections for good contact. Clean connector terminals thoroughly with electrical contact cleaner, apply dielectric grease and reconnect. 9. Contact an Authorized Service Dealer. 10. Clean, adjust or replace spark plug. 11. Check the spark plug wire connection.
Engine loses power	<ol style="list-style-type: none"> 1. Engine load is excessive 2. Air cleaner is dirty. 3. Oil level in the crankcase is low. 4. Cooling fins and air passages for the engine are plugged. 5. Vent hole in the fuel cap is plugged. 6. Dirt in fuel filter. 7. Dirt, water, or stale fuel is in the fuel system. 	<ol style="list-style-type: none"> 1. Reduce the ground speed. 2. Clean or replace the air cleaner element. 3. Add oil to the crankcase. 4. Remove the obstructions from the cooling fins and air passages. 5. Clean or replace the fuel cap. 6. Replace the fuel filter. 7. Contact an Authorized Service Dealer.

Troubleshooting

Problem	Possible Cause	Corrective Action
Engine overheats	<ol style="list-style-type: none"> 1. Engine load is excessive 2. Oil level in the crankcase is low. 3. Cooling fins and air passages for the engine are plugged. 	<ol style="list-style-type: none"> 1. Reduce the ground speed. 2. Add oil to the crankcase. 3. Remove the obstructions from the cooling fins and air passages.
Mower pulls left or right (with levers fully forward)	<ol style="list-style-type: none"> 1. Tracking needs adjustment 2. Tire pressure in drive tires not correct. 3. Reverse indicator and motion control linkage need adjustment. 	<ol style="list-style-type: none"> 1. Adjust the tracking. 2. Adjust tire pressure in the drive tires. 3. Adjust the reverse indicator and the motion control linkage.
Machine does not drive	<ol style="list-style-type: none"> 1. Bypass valve is not closed tight. 2. Drive or pump belt is worn, loose or broken. 3. Drive or pump belt is off a pulley. 4. Broken or missing idler spring 5. Hydraulic fluid level is low or too hot. 	<ol style="list-style-type: none"> 1. Tighten the bypass valve. 2. Change the belt. 3. Change the belt. 4. Replace the spring. 5. Add hydraulic fluid to reservoir or let it cool down.
Abnormal vibration	<ol style="list-style-type: none"> 1. Engine mounting bolts are loose. 2. Loose engine pulley, idler pulley, or blade pulley. 3. Engine pulley is damaged. 	<ol style="list-style-type: none"> 1. Tighten the engine mounting bolts. 2. Tighten the appropriate pulley. 3. Contact an Authorized Service Dealer.

Schematics

Electrical Diagram —23HP & 27HP Kohler

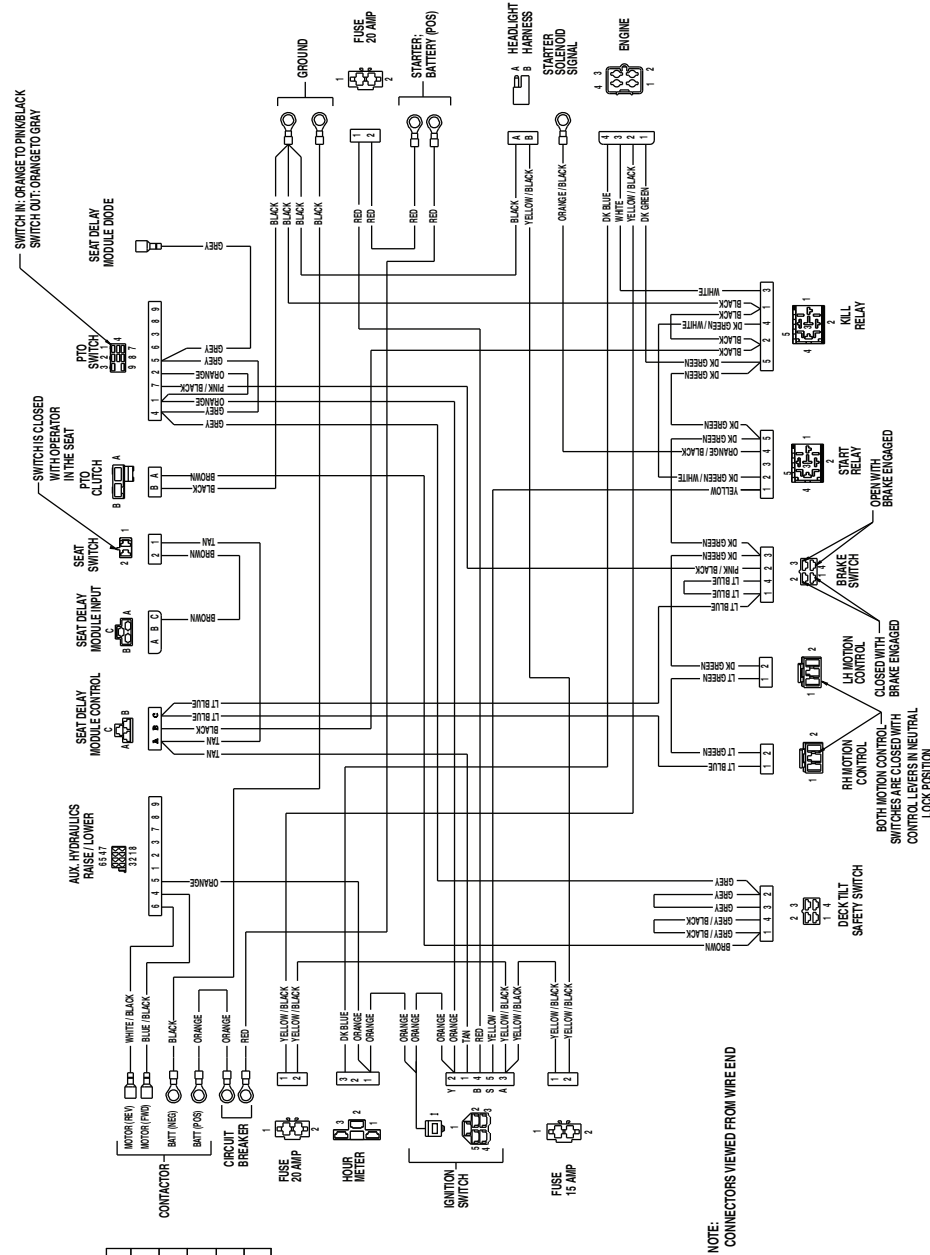

IGNITION SWITCH

TERMINAL	CONNECTIONS
TERMINAL A	VOLTAGE REGULATOR
TERMINAL B	BATTERY
TERMINAL I	HOUR METER, AUX PTO, PTO SWITCH
TERMINAL S	START RELAY
TERMINAL X	SEAT DELAY
TERMINAL Y	HOUR METER, AUX PTO, PTO SWITCH

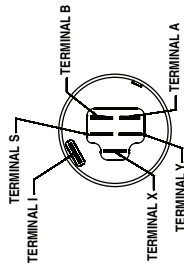

POSITION	CIRCUIT "MAKE"
1. OFF	NONE
2. RUN	B + I + A X + Y
3. START	B + I + S

NOTE:
CONNECTORS VIEWED FROM WIRE END

G007220

Electrical Diagram – 31HP Briggs & Stratton

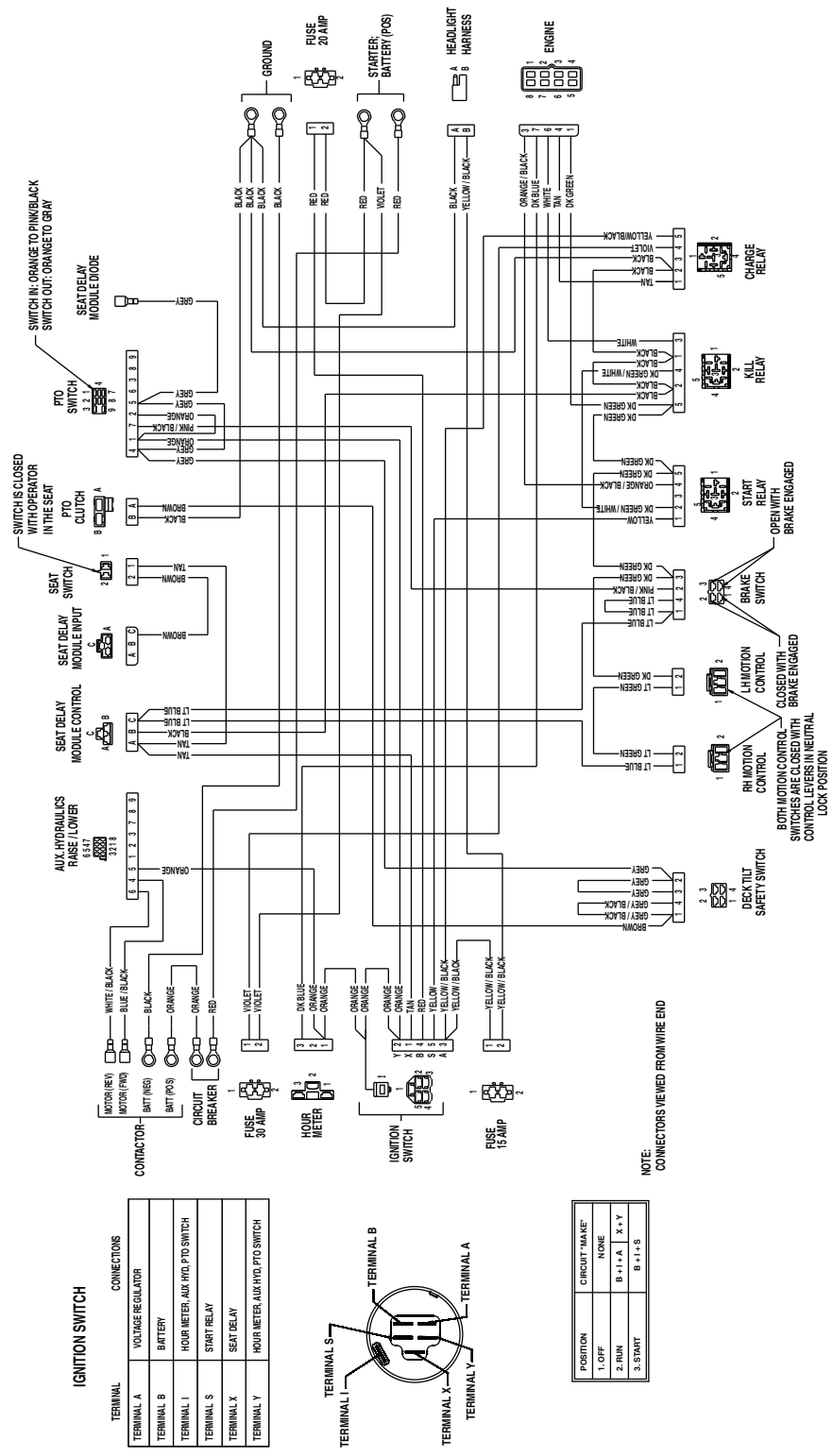

IGNITION SWITCH

TERMINAL	CONNECTIONS
TERMINAL A	VOLTAGE REGULATOR
TERMINAL B	BATTERY
TERMINAL I	HOUR METER, AUX. PTO SWITCH
TERMINAL S	START RELAY
TERMINAL X	SEAT DELAY
TERMINAL Y	HOUR METER, AUX. PTO SWITCH

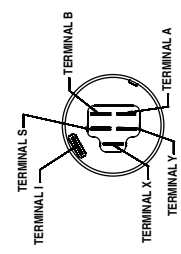

POSITION	CIRCUIT MAKE
1. OFF	NONE
2. RUN	B + I + A X + Y
3. START	B + I + S

NOTE: CONNECTORS VIEWED FROM WIRE END

G007221

Hydraulic Diagram

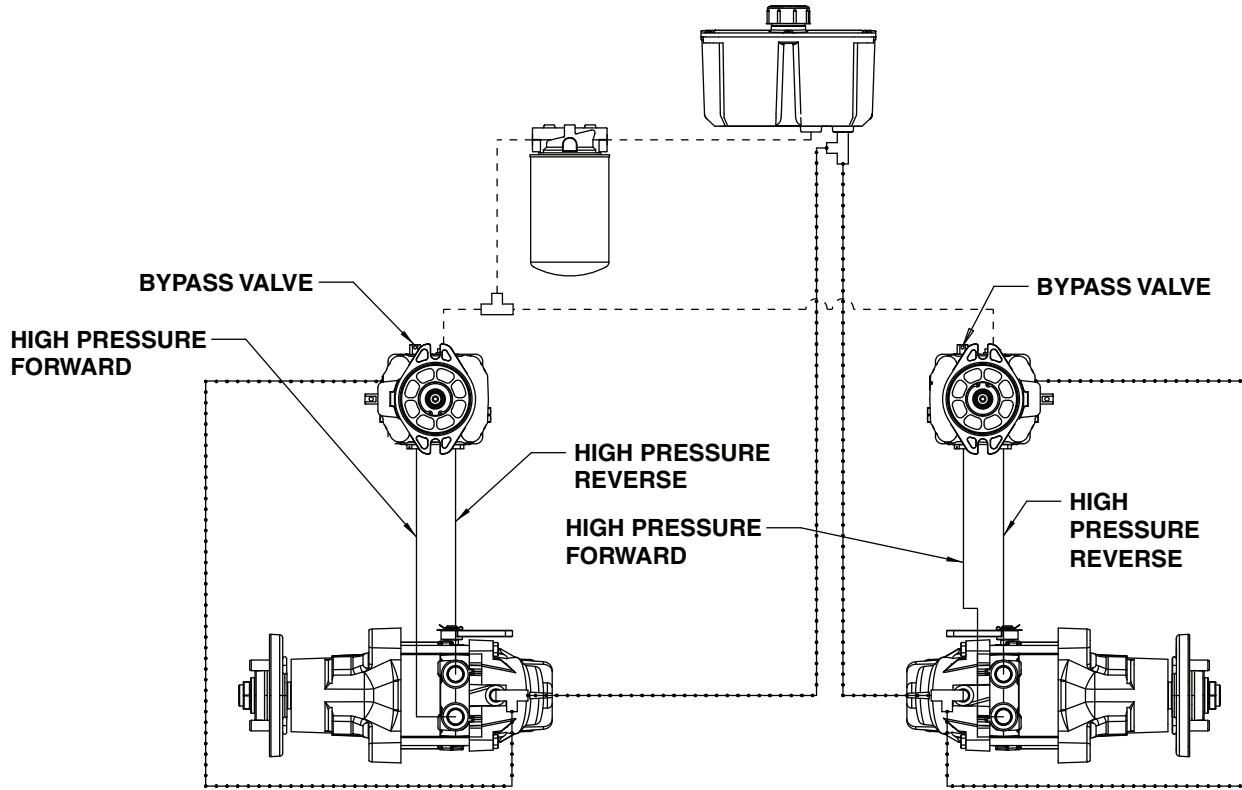

G007220

- HIGH PRESSURE
- - - - CHARGE PUMP
- CASE DRAIN

2-Year Limited Warranty Exmark Turf Equipment

(For units purchased on or after October 1, 2004)

Conditions and Products Covered

Exmark Mfg. Co. Inc. and its affiliate, Exmark Warranty Company, pursuant to an agreement between them, jointly warrant on the terms and conditions herein, that we will repair, replace or adjust any part manufactured by Exmark and found by us (in the exercise of our reasonable discretion) to be defective in factory materials or workmanship for a period of two years.

This warranty applies to Exmark turf equipment purchased on or after October 1, 2004 sold in the US or Canada. This warranty may only be assigned or transferred to a second (or third) owner by an authorized Exmark dealer. The warranty period commences upon the date of the original retail purchase.

<u>Products</u>	<u>Warranty Period</u>
• All Products (except as noted below)	2 years
• All Attachments and Accessories	1 year
• Metro 21 and Metro 26 Series	1 year
• Belts and Tires	90 days
• Battery	1 Year Prorated
• Engine*	Warranty is covered by engine manufacturer

* Please refer to the engine manufacturer's warranty statement that is included in the literature packet. We are not authorized to handle warranty adjustments on engines.

This warranty only includes the cost of parts and labor.

Items and Conditions Not Covered

This warranty does not cover the following:

- Pickup and delivery charges to and from any authorized Exmark Service Dealer beyond first warrantable service.
- Any damage or deterioration due to normal use, wear and tear, or exposure.
- Cost of regular maintenance service or parts, such as filters, fuel, lubricants, tune-up parts, and adjustments.
- Any product or part which has been altered or misused or required replacement or repair due to normal wear, accidents, or lack of proper maintenance.
- Any repairs necessary due to use of parts, accessories or supplies, including gasoline, oil or lubricants, incompatible with the turf equipment or other than as recommended in the operator's manual or other operational instructions provided by Exmark.

There are no other express warranties except for engine and special emission system coverage stated elsewhere herein or included with the product.

All warranty work must be performed by an authorized Exmark Service Dealer using Exmark approved replacement parts.

Instructions for Obtaining Warranty Service

The product must be registered with original proof of purchase by an Exmark Service Dealer before obtaining any warranty service.

Contact any Exmark Service Dealer to arrange service at their dealership. To locate a dealer convenient to you, access our website at www.exmark.com. U.S. Customers may also call 402-223-6375.

If for any reason you are dissatisfied with the Service Dealer's analysis or with the assistance provided, contact us at:

Exmark Customer Service Department
The Exmark Warranty Company
2101 Ashland Avenue
Beatrice, NE 68310
402-223-6375 or
service@exmark.com

Owner's Responsibilities

The Exmark turf equipment, including any defective part, must be returned to an authorized Exmark service dealer within the warranty period. This warranty extends only to turf equipment operated under normal conditions. You must read the operator's manual. You must also properly service and maintain your Exmark product as described in the operator's manual. Such routine maintenance, whether performed by a dealer or by you, is at your expense.

General Conditions

The sole liability of Exmark and Exmark Warranty Company with respect to this warranty shall be repair and replacement of defective components as set forth herein. **Neither Exmark nor Exmark Warranty Company shall have any liability for any other cost, loss or damage, including but not limited to, any incidental or consequential loss or damage.**

In particular, we shall have no liability or responsibility for:

- Expenses related to gasoline, oil or lubricants.
- Travel time, overtime, after hours time or other extraordinary repair charges or charge relating to repairs or replacements outside of normal business hours at the place of business of the authorized Exmark Service Dealer.
- Rental of like or similar replacement equipment during the period of any warranty, repair or replacement work.
- Any telephone or telegram charges or travel charges.
- Loss or damage to person or property other than that covered by the terms of this warranty.
- Any claims for lost revenue, lost profit or additional cost as a result of a claim of breach of warranty.
- Attorney's fees.

No Claim of breach of warranty shall be cause for cancellation or rescission of the contract of sale of any Exmark mower.

Some states do not allow exclusions of incidental or consequential damages, so the above exclusions and limitations may not apply to you.

This warranty gives you specific legal rights, and you may also have other rights which vary from state to state.

G006117

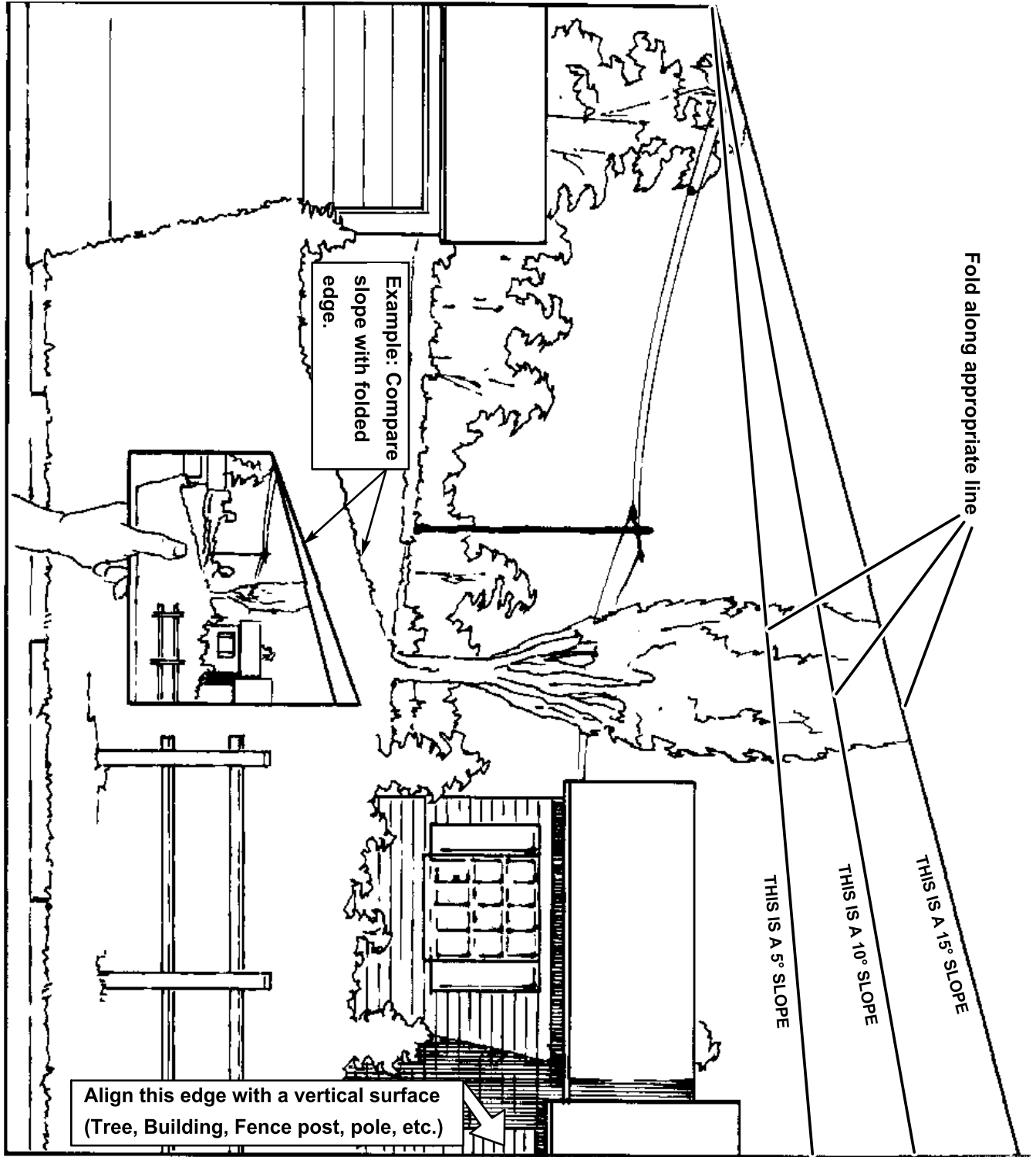

SEE EXMARK'S COMPLETE LINE OF ACCESSORIES

MID-MOUNT RIDING ACCESSORIES

CUSTOM RIDE SEAT SUSPENSION SYSTEM	ROLL OVER PROTECTION SYSTEM (ROPS)
DECK LIFT ASSIST KIT	SNOW BLADE
HITCH KIT	SUN SHADE
LAZERLOCKER	TRASH CONTAINER
LIGHT KIT	TURF STRIPER
MICRO-MULCH SYSTEM	ULTRA VAC COLLECTION SYSTEM
OPERATOR CONTROLLED DISCHARGE	ULTRA VAC QUICK DISPOSAL SYSTEM

OUT-FRONT RIDING ACCESSORIES

CUSTOM RIDE SEAT SUSPENSION SYSTEM	SNOW BLADE
DUAL-TAIL WHEEL	SNOWBLOWER
FLOOR PAN EXTENDER	SUN SHADE
HITCH KIT	TRASH CONTAINER
LIGHT KIT	ULTRA VAC COLLECTION SYSTEM
MICRO-MULCH SYSTEM	ULTRA VAC QUICK DISPOSAL SYSTEM
ROLL OVER PROTECTION SYSTEM (ROPS)	WEATHER CAB
ROTARY BROOM	

WALK-BEHIND ACCESSORIES

GRASS CATCHER	TURF STRIPER
LAZERLOCKER	STANDON
MICRO-MULCH SYSTEM	

Place Model No. and Serial No.
Label Here (Included in the Literature
Pack) or Fill in Below

Model No. _____

Serial No. _____

Date Purchased _____

Engine Model No. and Spec. No. _____

Engine Serial No. (E/No) _____

© 2004–2008 Exmark Mfg. Co., Inc.
Industrial Park Box 808
Beatrice, NE 68310
All Rights Reserved

Part No. 4500-218 Rev. A
(402) 223-6300
Fax (402) 223-5489
Printed in the USA.

